

1 6 June 2013  
2 **EMA/873138/2011** Rev 1\*

3 **Guideline on good pharmacovigilance practices (GVP)**  
4 **Module VI – Management and reporting of adverse reactions to medicinal**  
5 **products (Rev 1)**

|  |               |
|--|---------------|
| Date for coming into effect of first version   | 2 July 2012   |
| Draft Revision 1* finalised by the Agency in collaboration with Member States        | 28 May 2013   |
| Draft Revision 1 agreed by ERMS FG   | 29 May 2013   |
| Draft Revision 1 adopted by Executive Director                                       | 6 June 2013   |
| Released for public consultation   | 7 June 2013   |
| End of consultation (deadline for comments)  | 5 August 2013 |
| Revised draft Revision 1 finalised by the Agency in collaboration with Member States |               |
| Revised draft Revision 1 agreed by ERMS FG   |               |
| Revised draft Revision 1 adopted by Executive Director as final                      |               |
| Date for coming into effect of Revision 1  | Q 4 2013      |

- 6
- 7 \* **Note:** Revision 1 contains the following to address questions received from stakeholders:
- 8 - Clarifications on the clock start for the reporting of valid ICSRs in VI.B.7.;
- 9 - Clarifications on the reporting of suspected adverse reactions originating in post authorisation studies
- 10 in VI.C.1.2.;
- 11 - Clarifications on the handling of ICSRs when reported in an official language in VI.C.6.2.2.9.;
- 12 - Clarifications on the electronic reporting for ICSRs from market research programmes in
- 13 VI.C.6.2.3.7.;
- 14 - Replacements of tables highlighting interim arrangements applicable to marketing authorisation
- 15 holders in VI.App.3.1.1.;
- 16 - Revisions in VI.A.2.1.1., VI.A.2.4., VI.B.6.3., VI.C.1. and VI.C.2.2.2..
- 17

See websites for contact details



Comments should be provided using this [template](#). The completed comments form should be sent to [gvp@ema.europa.eu](mailto:gvp@ema.europa.eu).

18

19 Note for public consultation:

20 The public consultation is restricted to the yellow highlighted revised texts (i.e. replaced by new texts  
21 with deletions and additions) or deleted texts (i.e. not replaced). However, if revisions or deletions  
22 impact or contradict other existing text, comments on such non-highlighted texts will be processed and  
23 taken into account for the finalisation process.

24

## 25 **TABLE OF CONTENTS**

|    |  |           |
|----|--|-----------|
| 26 | <b>VI.A. Introduction</b> .....  | <b>6</b>  |
| 27 | VI.A.1. Scope .....  | 6         |
| 28 | VI.A.2. Definitions.....   | 6         |
| 29 | VI.A.2.1. Adverse reaction .....   | 6         |
| 30 | VI.A.2.1.1. Causality .....  | 6         |
| 31 | VI.A.2.1.2. Overdose, off-label use, misuse, abuse, occupational exposure .....                                  | 7         |
| 32 | VI.A.2.2. Medicinal product .....  | 7         |
| 33 | VI.A.2.3. Primary source.....  | 8         |
| 34 | VI.A.2.4. Seriousness .....  | 8         |
| 35 | VI.A.2.5. Individual Case Safety Report (ICSR).....  | 9         |
| 36 | <b>VI.B. Structures and Processes</b> .....  | <b>10</b> |
| 37 | VI.B.1. Collection of reports .....  | 10        |
| 38 | VI.B.1.1. Unsolicited reports.....   | 10        |
| 39 | VI.B.1.1.1. Spontaneous reports.....   | 10        |
| 40 | VI.B.1.1.2. Literature reports .....   | 11        |
| 41 | VI.B.1.1.3. Reports from other sources.....  | 11        |
| 42 | VI.B.1.1.4. Information on suspected adverse reactions from the internet or digital media.....                   | 11        |
| 43 | VI.B.1.2. Solicited reports .....  | 12        |
| 44 | VI.B.2. Validation of reports .....  | 12        |
| 45 | VI.B.3. Follow-up of reports .....   | 14        |
| 46 | VI.B.4. Data management .....  | 14        |
| 47 | VI.B.5. Quality management .....   | 15        |
| 48 | VI.B.6. Special situations .....   | 16        |
| 49 | VI.B.6.1. Use of a medicinal product during pregnancy or breastfeeding .....                                     | 16        |
| 50 | VI.B.6.2. Use of a medicinal product in a paediatric or elderly population.....                                  | 17        |
| 51 | VI.B.6.3. Reports of overdose, abuse, off-label use, misuse, medication error or occupational exposure .....     | 17        |
| 52 | VI.B.6.4. Lack of therapeutic efficacy .....   | 17        |
| 53 | VI.B.7. Reporting of ICSRs .....   | 18        |
| 54 | VI.B.7.1. Reporting time frames .....  | 18        |
| 55 | VI.B.8. Reporting modalities.....  | 19        |
| 56 |  |           |
| 57 | <b>VI.C. Operation of the EU Network</b> .....   | <b>20</b> |
| 58 | VI.C.1. Interface with safety reporting rules for clinical trials and post authorisation studies in the EU ..... | 20        |
| 59 | VI.C.1.1. Interface with clinical trials .....   | 21        |
| 60 | VI.C.1.2. Interface with post-authorisation studies.....   | 22        |
| 61 | VI.C.1.2.1. Non-interventional studies .....   | 23        |
| 62 | VI.C.1.2.2. Compassionate use, named patient use.....  | 24        |
| 63 | VI.C.2. Collection of reports .....  | 24        |
| 64 | VI.C.2.1. Member States responsibilities .....   | 24        |
| 65 | VI.C.2.2. Marketing authorisation holders responsibilities.....  | 25        |
| 66 | VI.C.2.2.1. Spontaneous reports.....   | 26        |
| 67 | VI.C.2.2.2. Solicited reports .....  | 26        |
| 68 |  |           |

|     |  |    |
|-----|--|----|
| 69  | VI.C.2.2.3. Case reports published in the scientific and medical literature .....            | 27 |
| 70  | VI.C.2.2.4. Suspected adverse reactions related to quality defect or falsified medicinal     |    |
| 71  | products .....   | 28 |
| 72  | VI.C.2.2.5. Suspected transmission via a medicinal product of an infectious agent .....      | 28 |
| 73  | VI.C.2.2.6. Emerging safety issues.....  | 29 |
| 74  | VI.C.2.2.7. Period between the submission of the marketing authorisation application and     |    |
| 75  | the granting of the marketing authorisation .....  | 29 |
| 76  | VI.C.2.2.8. Period after suspension, revocation or withdrawal of marketing authorisation ..  | 30 |
| 77  | VI.C.2.2.9. Period during a public health emergency .....                                    | 30 |
| 78  | VI.C.2.2.10. Reports from class action lawsuits .....  | 30 |
| 79  | VI.C.2.2.11. Reports from patient support programmes and market research programmes          | 30 |
| 80  | VI.C.3. Reporting time frames .....  | 31 |
| 81  | VI.C.4. Reporting modalities.....  | 31 |
| 82  | VI.C.4.1. Interim arrangements.....  | 32 |
| 83  | VI.C.4.2. Final arrangements.....  | 32 |
| 84  | VI.C.5. Collaboration with the World Health Organization and the European Monitoring         |    |
| 85  | Centre for Drugs and Drug Addiction .....  | 33 |
| 86  | VI.C.6. Electronic exchange of safety information in the EU.....                             | 33 |
| 87  | VI.C.6.1. Applicable guidelines, definitions, international formats, standards and           |    |
| 88  | terminologies .....  | 34 |
| 89  | VI.C.6.2. Electronic Reporting of Individual Case Safety Reports .....                       | 34 |
| 90  | VI.C.6.2.1. EudraVigilance Database Modules .....  | 34 |
| 91  | VI.C.6.2.1.1. Adverse reaction data collected in the EudraVigilance Post-Authorisation       |    |
| 92  | Module .....   | 35 |
| 93  | VI.C.6.2.1.2. Adverse Reaction Data Collected in the EudraVigilance Clinical Trial Module .. | 35 |
| 94  | VI.C.6.2.2. Preparation of Individual Case Safety Reports .....                              | 35 |
| 95  | VI.C.6.2.2.1. General principles .....   | 35 |
| 96  | VI.C.6.2.2.2. Information on suspect, interacting and concomitant medicinal products .....   | 36 |
| 97  | VI.C.6.2.2.3. Suspected adverse reactions .....  | 38 |
| 98  | VI.C.6.2.2.4. Case narrative, causality assessment and comments.....                         | 38 |
| 99  | VI.C.6.2.2.5. Test results.....  | 39 |
| 100 | VI.C.6.2.2.6. Supplementary information.....   | 39 |
| 101 | VI.C.6.2.2.7. Follow-up information.....   | 40 |
| 102 | VI.C.6.2.2.8. What to take into account for data privacy laws.....                           | 41 |
| 103 | VI.C.6.2.2.9. Handling of languages.....   | 41 |
| 104 | VI.C.6.2.2.10. Nullification of cases.....   | 42 |
| 105 | VI.C.6.2.3. Special situations .....   | 42 |
| 106 | VI.C.6.2.3.1. Use of a medicinal product during pregnancy or breastfeeding .....             | 42 |
| 107 | VI.C.6.2.3.2. Suspected adverse reaction reports published in the scientific and medical     |    |
| 108 | literature .....   | 43 |
| 109 | VI.C.6.2.3.3. Suspected adverse reactions related to overdose, abuse, off-label use, misuse, |    |
| 110 | medication error or occupational exposure .....  | 43 |
| 111 | VI.C.6.2.3.4. Lack of therapeutic efficacy.....  | 44 |
| 112 | VI.C.6.2.3.5. Suspected adverse reactions related to quality defect or falsified medicinal   |    |
| 113 | products .....   | 44 |
| 114 | VI.C.6.2.3.6. Suspected transmission via a medicinal product of an infectious agent .....    | 44 |
| 115 | VI.C.6.2.3.7. Reports originating from organised data collection systems and other systems   |    |
| 116 | .....  | 45 |

|     |   |           |
|-----|---|-----------|
| 117 | VI.C.6.2.3.8. Receipt of missing minimum information .....                                      | 46        |
| 118 | VI.C.6.2.4. Data quality of individual case safety reports transmitted electronically and       |           |
| 119 | duplicate management .....  | 46        |
| 120 | VI.C.6.2.5. Electronic re-transmission of ICSRs between multiple senders and receivers ....     | 47        |
| 121 | VI.C.6.2.6. Electronic reporting through company's headquarters .....                           | 48        |
| 122 | VI.C.6.3. Electronic submission of information on medicinal products .....                      | 48        |
| 123 | <b>VI. APPENDICES .....</b>   | <b>49</b> |
| 124 | <b>VI. Appendix 1 Identification of biological medicinal products .....</b>                     | <b>50</b> |
| 125 | <b>VI. Appendix 2 Detailed guidance on the monitoring of scientific and</b>                     |           |
| 126 | <b>medical literature .....</b>   | <b>53</b> |
| 127 | VI.App2.1. When to start and stop searching in the scientific and medical literature .....      | 53        |
| 128 | VI.App2.2. Where to look .....  | 53        |
| 129 | VI.App2.3. Database Searches .....  | 54        |
| 130 | VI.App2.3.1. Precision and recall .....   | 54        |
| 131 | VI.App2.3.2. Search construction .....  | 54        |
| 132 | VI.App2.3.3. Selection of product terms .....   | 54        |
| 133 | VI.App2.3.4. Selection of search terms .....  | 55        |
| 134 | VI.App2.3.5. Limits to a search .....   | 55        |
| 135 | VI.App2.4. Record keeping .....   | 56        |
| 136 | VI.App2.5. Outputs .....  | 56        |
| 137 | VI.App2.6. Review and selection of articles .....   | 56        |
| 138 | VI.App2.7. Day zero .....   | 57        |
| 139 | VI.App2.8. Duplicates .....   | 57        |
| 140 | VI.App2.9. Contracting out Literature Search Services .....                                     | 57        |
| 141 | VI.App2.10. Electronic submission of copies of articles published in the scientific and medical |           |
| 142 | literature .....  | 57        |
| 143 | <b>VI. Appendix 3 Modalities for reporting .....</b>  | <b>62</b> |
| 144 | VI.App3.1. Interim arrangements .....   | 62        |
| 145 | VI.App3.1.1. Interim arrangements applicable to marketing authorisation holders .....           | 68        |
| 146 | VI.App3.1.2. Interim arrangements applicable to competent authorities in Member States .....    | 70        |
| 147 | VI.App3.2. Final arrangements .....   | 71        |
| 148 | VI.App3.2.1. Final arrangements applicable to marketing authorisation holders .....             | 74        |
| 149 | VI.App3.2.2. Final arrangements applicable to competent authorities in Member States .....      | 74        |
| 150 | VI.App3.3. Transmission and rerouting of ICSRs to competent authorities in Member States        |           |
| 151 | .....   | 75        |
| 152 | <b>VI. Appendix 4 Transmission of ICSRs to World Health Organization (WHO)</b>                  |           |
| 153 | .....   | <b>79</b> |
| 154 | <b>VI. Appendix 5 Nullification of cases .....</b>  | <b>83</b> |
| 155 | <b>VI. Appendix 6 Data quality monitoring of ICSRs transmitted electronically</b>               |           |
| 156 | .....   | <b>87</b> |
| 157 | <b>VI. Appendix 7 Duplicate detection and management of ICSRs .....</b>                         | <b>90</b> |
| 158 |   |           |
| 159 |   |           |

## 160 **VI.A. Introduction**

### 161 **VI.A.1. Scope**

162 This Module addresses the legal requirements detailed in Title IX of Directive 2001/83/EC [DIR] and  
163 Chapter 3 of Regulation (EC) No 726/2004 [REG], which are applicable to competent authorities in  
164 Member States, marketing authorisation holders and the Agency as regards the collection, data  
165 management and reporting of suspected adverse reactions (serious and non-serious) associated with  
166 medicinal products for human use authorised in the European Union (EU). Recommendations regarding  
167 the reporting of emerging safety issues or of suspected adverse reactions occurring in special  
168 situations are also presented in this Module. The requirements provided in Chapter IV, V and IX of the  
169 Commission Implementing Regulation (EU) No 520/2012 [IR] shall be applied in this Module.

170 The guidance provided in this Module does not address the collection, management and reporting of  
171 events or patterns of use, which do not result in suspected adverse reactions (e.g. asymptomatic  
172 overdose, abuse, off-label use, misuse or medication error) or which do not require to be reported as  
173 individual case safety report or as Emerging Safety Issues. This information may however need to be  
174 collected and presented in periodic safety update reports for the interpretation of safety data or for the  
175 benefit risk evaluation of medicinal products. In this aspect, guidance provided in **Module VII** applies.

176 All applicable legal requirements detailed in this Module are referenced in the way explained in the GVP  
177 Introductory Cover Note and are usually identifiable by the modal verb “shall”. Guidance for the  
178 implementation of legal requirements is provided using the modal verb “should”.

### 179 **VI.A.2. Definitions**

180 The definitions provided in Article 1 of Directive 2001/83/EC shall be applied for the purpose of this  
181 Module; of particular relevance are those provided in this chapter. Some general principles presented  
182 in the ICH-E2A and ICH-E2D guidelines<sup>1</sup> should also be adhered to; they are included as well in this  
183 chapter.

#### 184 **VI.A.2.1. Adverse reaction**

185 An adverse reaction is a response to a medicinal product which is noxious and unintended [DIR Art 1].  
186 This includes adverse reactions which arise from:

- 187 • the use of a medicinal product within the terms of the marketing authorisation;
- 188 • the use outside the terms of the marketing authorisation, including overdose, off-label use,  
189 misuse, abuse and medication errors;
- 190 • occupational exposure.

##### 191 **VI.A.2.1.1. Causality**

192 In accordance with the ICH-E2A guideline, the definition of an adverse reaction implies at least a  
193 reasonable possibility of a causal relationship between a suspected medicinal product and an adverse  
194 event. An adverse reaction, in contrast to an adverse event, is characterised by the fact that a causal  
195 relationship between a medicinal product and an occurrence is suspected. For regulatory reporting  
196 purposes, as detailed in the ICH-E2D guideline, if an event is spontaneously reported, even if the

---

<sup>1</sup> <http://www.ich.org/products/guidelines/efficacy/article/efficacy-guidelines.html>

197 relationship is unknown or unstated, it meets the definition of an adverse reaction. Therefore all  
198 spontaneous reports notified by healthcare professionals, patients or consumers are considered  
199 suspected adverse reactions, since they convey the suspicions of the primary sources, unless the  
200 reporters specifically state that they believe the events to be unrelated or that a causal relationship  
201 can be excluded.

#### 202 **VI.A.2.1.2. Overdose, off-label use, misuse, abuse, occupational exposure**

##### 203 **a. Overdose**

204 This refers to the administration of a quantity of a medicinal product given per administration or  
205 cumulatively, which is above the maximum recommended dose according to the authorised product  
206 information. Clinical judgement should always be applied.

##### 207 **b. Off-label use**

208 This relates to situations where the medicinal product is intentionally used for a medical purpose not in  
209 accordance with the authorised product information.

##### 210 **c. Misuse**

211 This refers to situations where the medicinal product is intentionally and inappropriately used not in  
212 accordance with the authorised product information.

##### 213 **d. Abuse**

214 This corresponds to the persistent or sporadic, intentional excessive use of a medicinal product, which  
215 is accompanied by harmful physical or psychological effects [DIR Art 1].

##### 216 **e. Occupational exposure**

217 This refers to the exposure to a medicinal product (as defined in [DIR Art 1]), as a result of one's  
218 professional or non-professional occupation.

#### 219 **VI.A.2.2. Medicinal product**

220 A medicinal product is characterised by any substance or combination of substances,

- 221 • presented as having properties for treating or preventing disease in human beings; or
- 222 • which may be used in or administered to human beings either with a view to restoring, correcting  
223 or modifying physiological functions by exerting a pharmacological, immunological or metabolic  
224 action, or to making a medical diagnosis [DIR Art 1].

225 In accordance with Article 107 of Directive 2001/83/EC, the scope of this module is not only applicable  
226 to medicinal products authorised in the EU but also to any such medicinal products commercialised  
227 outside the EU by the same marketing authorisation holder (see [VI.C.2.2.](#)). Given that a medicinal  
228 product is authorised with a defined composition, all the adverse reactions suspected to be related to  
229 any of the active substances being part of a medicinal product authorised in the EU should be managed  
230 in accordance with the requirements presented in this module. This is valid independently of the  
231 strengths, pharmaceutical forms, routes of administration, presentations, authorised indications, or  
232 trade names of the medicinal product.

233 The guidance provided in this Module also applies, subject to amendments where appropriate, to  
234 medicinal products supplied in the context of compassionate use (see [VI.C.1.2.2.](#)) as defined in Article

235 83(2) of Regulation (EC) No 726/2004. As the case may be, this guidance may also apply to named  
236 patient use as defined under Article 5(1) of Directive 2001/83/EC.

### 237 **VI.A.2.3. Primary source**

238 The primary source of the information on a suspected adverse reaction(s) is the person who reports  
239 the facts. Several primary sources, such as healthcare professionals and/or a consumer, may provide  
240 information on the same case. In this situation, all the primary sources' details, including the  
241 qualifications, should be provided in the case report, with the "Primary source(s)" section repeated as  
242 necessary in line with the ICH-E2B(R2) guideline<sup>2</sup>.

243 In accordance with the ICH-E2D guideline,

- 244 • a healthcare professional is defined as a medically-qualified person such as a physician, dentist,  
245 pharmacist, nurse, coroner or as otherwise specified by local regulations;
- 246 • a consumer is defined as a person who is not a healthcare professional such as a patient, lawyer,  
247 friend, relative of a patient or carer.

248 Medical documentations (e.g. laboratory or other test data) provided by a consumer that support the  
249 occurrence of the suspected adverse reaction, or which indicate that an identifiable healthcare  
250 professional suspects a reasonable possibility of causal relationship between a medicinal product and  
251 the reported adverse event, are sufficient to consider the spontaneous report as confirmed by a  
252 healthcare professional.

253 If a consumer initially reports more than one reaction and at least one receives medical confirmation,  
254 the whole report should be documented as a spontaneous report confirmed by a healthcare  
255 professional and be reported accordingly. Similarly, if a report is submitted by a medically qualified  
256 patient, friend, relative of the patient or carer, the case should also be considered as a spontaneous  
257 report confirmed by a healthcare professional.

### 258 **VI.A.2.4. Seriousness**

259 As described in the ICH-E2A guideline, a serious adverse reaction corresponds to any untoward  
260 medical occurrence that at any dose results in death, is life-threatening, requires inpatient  
261 hospitalisation or prolongation of existing hospitalisation, results in persistent or significant disability or  
262 incapacity, **or** is a congenital anomaly/birth defect.

263 The characteristics/consequences should be considered at the time of the reaction to determine the  
264 seriousness of a case. For example, life-threatening refers to a reaction in which the patient was at risk  
265 of death at the time of the reaction; it does not refer to a reaction that hypothetically might have  
266 caused death if more severe.

267 Medical judgement should be exercised in deciding whether other situations should be considered as  
268 serious reactions. Some medical events may jeopardise the patient or may require an intervention to  
269 prevent one of the above characteristics/consequences. Such important medical events should be  
270 considered as serious<sup>3</sup>. The EudraVigilance Expert Working Group has co-ordinated the development of  
271 an important medical event (IME) terms list based on the Medical Dictionary for Regulatory Activities  
272 (MedDRA). This IME list aims to facilitate the classification of suspected adverse reactions, the analysis  
273 of aggregated data and the assessment of the Individual Case Safety Reports (ICSRs) in the  
274 framework of the day-to-day pharmacovigilance activities. The IME list is intended for guidance

---

<sup>2</sup> See [VI.C.6](#) as regards the electronic reporting of ICSRs in the EU.

<sup>3</sup> Examples are provided in Section II.B of ICH E2A guideline.



275 purposes only and is available on the EudraVigilance web site<sup>4</sup> to stakeholders who wish to use it for  
276 their pharmacovigilance activities. It is regularly updated in line with the latest version of MedDRA.

#### 277 **VI.A.2.5. Individual Case Safety Report (ICSR)**

278 This refers to the format and content for the reporting of one or several suspected adverse reactions in  
279 relation to a medicinal product that occur in a single patient at a specific point of time. A valid ICSR  
280 should include at least one identifiable reporter, one single identifiable patient, at least one suspect  
281 adverse reaction and at least one suspect medicinal product.

---

<sup>4</sup> (<http://eudravigilance.ema.europa.eu/human/textforIME.asp>).

## 282 **VI.B. Structures and Processes**

283 Section B of this Module highlights the general principles in relation to the collection, recording and  
284 reporting of reports of suspected adverse reactions associated with medicinal products for human use,  
285 which are applicable to competent authorities and marketing authorisation holders. The definitions and  
286 recommendations provided in [VI.A](#) should be followed. EU requirements are presented in [VI.C](#).

### 287 **VI.B.1. Collection of reports**

288 Competent authorities and marketing authorisation holders should take appropriate measures in order  
289 to collect and collate all reports of suspected adverse reactions associated with medicinal products for  
290 human use originating from unsolicited or solicited sources.

291 For this purpose, a pharmacovigilance system should be developed to allow the acquisition of sufficient  
292 information for the scientific evaluation of those reports.

293 The system should be designed so that it helps to ensure that the collected reports are authentic,  
294 legible, accurate, consistent, verifiable and as complete as possible for their clinical assessment.

295 All notifications that contain pharmacovigilance data should be recorded and archived in compliance  
296 with the applicable data protection requirements (see [VI.C.6.2.2.8](#) for EU recommendations).

297 The system should also be structured in a way that allows for reports of suspected adverse reactions to  
298 be validated (see [VI.B.2](#)) in a timely manner and exchanged between competent authorities and  
299 marketing authorisation holders within the legal reporting time frame (see [VI.B.7.1](#)).

300 In accordance with the ICH-E2D guideline, two types of safety reports are distinguished in the post-  
301 authorisation phase; reports originating from unsolicited sources and those reported as solicited.

### 302 **VI.B.1.1. Unsolicited reports**

#### 303 **VI.B.1.1.1. Spontaneous reports**

304 A spontaneous report is an unsolicited communication by a healthcare professional, or consumer to a  
305 competent authority, marketing authorisation holder or other organisation (e.g. Regional  
306 Pharmacovigilance Centre, Poison Control Centre) that describes one or more suspected adverse  
307 reactions in a patient who was given one or more medicinal products and that does not derive from a  
308 study or any organised data collection systems where adverse events reporting is actively sought, as  
309 defined in [VI.B.1.2](#).

310 Stimulated reporting that occurs consequent to a “Direct Healthcare Professional Communication”,  
311 publication in the press, questioning of healthcare professionals by company representatives,  
312 communication from patients’ organisations to their members, or class action lawsuits should be  
313 considered spontaneous reports.

314 Unsolicited consumer adverse reactions reports should be handled as spontaneous reports irrespective  
315 of any subsequent “medical confirmation”.

316 The reporting modalities and applicable time frames for spontaneous reports are described in [VI.B.7](#)  
317 and [VI.B.8](#).

318 **VI.B.1.1.2. Literature reports**

319 The scientific and medical literature is a significant source of information for the monitoring of the  
320 safety profile and of the risk-benefit balance of medicinal products, particularly in relation to the  
321 detection of new safety signals or emerging safety issues. Marketing authorisation holders are  
322 therefore expected to maintain awareness of possible publications through a systematic literature  
323 review of widely used reference databases (e.g. Medline, Excerpta Medica or Embase) no less  
324 frequently than once a week. The marketing authorisation holder should ensure that the literature  
325 review includes the use of reference databases that contain the largest reference of articles in relation  
326 to the medicinal product properties<sup>5</sup>. In addition, marketing authorisation holders should have  
327 procedures in place to monitor scientific and medical publications in local journals in countries where  
328 medicinal products have a marketing authorisation, and to bring them to the attention of the company  
329 safety department as appropriate.

330 Reports of suspected adverse reactions from the scientific and medical literature, including relevant  
331 published abstracts from meetings and draft manuscripts, should be reviewed and assessed by  
332 marketing authorisation holders to identify and record ICSRs originating from spontaneous reports or  
333 non-interventional post-authorisation studies.

334 If multiple medicinal products are mentioned in the publication, only those which are identified by the  
335 publication's author(s) as having at least a possible causal relationship with the suspected adverse  
336 reaction should be considered by the concerned marketing authorisation holder(s).

337 Valid ICSRs should be reported according to the modalities detailed in [VI.B.7](#) and [VI.B.8](#).

338 One case should be created for each single patient identifiable based on characteristics provided in  
339 [VI.B.2](#). Relevant medical information should be provided and the publication author(s) should be  
340 considered as the primary source(s).

341 EU specific requirements, as regards medicinal products and scientific and medical publications, which  
342 are not monitored by the Agency and for which valid ICSRs shall be reported by marketing  
343 authorisation holders, are provided in [VI.C.2.2.3](#).

344 **VI.B.1.1.3. Reports from other sources**

345 If a marketing authorisation holder becomes aware of a report of suspected adverse reactions  
346 originating from a non-medical source, for example the lay press or other media, it should be handled  
347 as a spontaneous report. Every attempt should be made to follow-up the case to obtain the minimum  
348 information that constitutes a valid ICSR. The same reporting time frames should be applied as for  
349 other spontaneous reports.

350 **VI.B.1.1.4. Information on suspected adverse reactions from the internet or digital media**

351 Marketing authorisation holders should regularly screen internet or digital media<sup>6</sup> under their  
352 management or responsibility, for potential reports of suspected adverse reactions. In this aspect,  
353 digital media is considered to be company sponsored if it is owned, paid for and/or controlled by the  
354 marketing authorisation holder<sup>7</sup>. The frequency of the screening should allow for potential valid ICSRs  
355 to be reported to the competent authorities within the appropriate reporting timeframe based on the

---

<sup>5</sup> See [VI. Appendix 2](#) for the detailed guidance on the monitoring of medical and scientific literature.

<sup>6</sup> Although not exhaustive, the following list should be considered as digital media: web site, web page, blog, vlog, social network, internet forum, chat room, health portal.

<sup>7</sup> A donation (financial or otherwise) to an organisation/site by a marketing authorisation holder does not constitute ownership, provided that the marketing authorisation holder does not control the final content of the site.

356 date the information was posted on the internet site/digital medium. Marketing authorisation holders  
357 may also consider utilising their websites to facilitate the collection of reports of suspected adverse  
358 reactions (see [VI.C.2.2.1.](#)).

359 If a marketing authorisation holder becomes aware of a report of suspected adverse reaction described  
360 in any non-company sponsored digital medium, the report should be assessed to determine whether it  
361 qualifies for reporting.

362 Unsolicited cases of suspected adverse reactions from the internet or digital media should be handled  
363 as spontaneous reports. The same reporting time frames as for spontaneous reports should be applied  
364 (see [VI.B.7.](#)).

365 In relation to cases from the internet or digital media, the identifiability of the reporter refers to the  
366 existence of a real person, that is, it is possible to verify the contact details of the reporter (e.g., an  
367 email address under a valid format has been provided). If the country of the primary source is missing,  
368 the country where the information was received, or where the review took place, should be used as the  
369 primary source country.

### 370 **VI.B.1.2. Solicited reports**

371 As defined in ICH-E2D guideline, solicited reports of suspected adverse reactions are those derived  
372 from organised data collection systems, which include clinical trials, non-interventional studies,  
373 registries, post-approval named patient use programmes, other patient support and disease  
374 management programmes, surveys of patients or healthcare providers, compassionate use or name  
375 patient use, or information gathering on efficacy or patient compliance. Adverse reactions reports  
376 obtained from any of these data collection systems should not be considered spontaneous. This is with  
377 the exception of suspected adverse reactions originating from certain compassionate use or named  
378 patient use where adverse events are not actively sought (see [VI.C.1.2.2.](#)).

379 For the purpose of safety reporting, solicited reports should be classified as study reports, and should  
380 have an appropriate causality assessment, to consider whether they refer to suspected adverse  
381 reactions and therefore meet the criteria for reporting.

382 General reporting rules for suspected adverse reactions occurring in organised data collection systems  
383 conducted in the EU under the scope of Directive 2001/83/EC, Regulation (EC) No 726/2004 or  
384 Directive 2001/20/EC, are presented in [VI.C.1.](#)

### 385 **VI.B.2. Validation of reports**

386 Only valid ICSRs qualify for reporting. All reports of suspected adverse reactions should therefore be  
387 validated before reporting them to the competent authorities to make sure that the minimum criteria  
388 for reporting are included in the reports (ICH-E2D guideline). This is:

- 389 • One or more identifiable reporter (primary source), characterised by qualification (e.g. physician,  
390 pharmacist, other healthcare professional, lawyer, consumer or other non-healthcare professional)  
391 name, initials or address<sup>8</sup>. Whenever possible, contact details for the reporter should be recorded  
392 so that follow-up activities can be performed. However, if the reporter does not wish to provide  
393 contact details, the ICSR should still be considered as valid providing the organisation who was  
394 informed of the case was able to confirm it directly with the reporter. All parties providing case  
395 information or approached for case information should be identifiable, not only the initial reporter.

---

<sup>8</sup> Local data privacy laws regarding patient's and reporter's identifiability might apply.

- 396 • One single identifiable patient characterised by initials, patient identification number, date of birth,  
397 age, age group or gender. The information should be as complete as possible<sup>9</sup>.
- 398 • One or more suspected substance/medicinal product (see [VI.A.2.2.](#)).
- 399 • One or more suspected adverse reaction (see [VI.A.2.1.](#)). If the primary source has made an  
400 explicit statement that a causal relationship between the medicinal product and the adverse event  
401 has been excluded and the receiver (competent authority or marketing authorisation holder)  
402 agrees with this, the report does not qualify as a valid ICSR since the minimum information is  
403 incomplete<sup>10</sup>. The report does not also qualify as a valid ICSR if it is reported that the patient  
404 experienced an unspecified adverse reaction and there is no information provided on the type of  
405 adverse reaction experienced. Similarly, the report is not valid if only an outcome (or consequence)  
406 is notified and (i) no further information about the clinical circumstances is provided to consider it  
407 as a suspected adverse reaction, or (ii) the primary source has not indicated a possible causal  
408 relationship with the suspected medicinal product. For instance a marketing authorisation holder is  
409 made aware that a patient was hospitalised or died, without any further information. In this  
410 particular situation, medical judgement should always be applied in deciding whether the notified  
411 information is an adverse reaction or an event. For example, a report of sudden death would  
412 usually need to be considered as a case of suspected adverse reaction and reported.

413 The lack of any of these four elements means that the case is considered incomplete and does not  
414 qualify for reporting. Competent authorities and marketing authorisation holders are expected to  
415 exercise due diligence in following up the case to collect the missing data elements. Reports, for which  
416 the minimum information is incomplete, should nevertheless be recorded within the pharmacovigilance  
417 system for use in on-going safety evaluation activities. Recommendations on the electronic reporting of  
418 valid ICSRs, when missing information has been obtained, are provided in [VI.C.6.2.3.8.](#)

419 When collecting reports of suspected adverse reactions via the internet or digital media, the term  
420 “identifiable” refers to the possibility of verification of the existence of a reporter and a patient (see  
421 [VI.B.1.1.4.](#)).

422 When one party (competent authority or a marketing authorisation holder) is made aware that the  
423 primary source may also have reported the suspected adverse reaction to another concerned party,  
424 the report should still be considered as a valid ICSR. All the relevant information necessary for the  
425 detection of the duplicate case should be included in the ICSR<sup>11</sup>.

426 A valid case of suspected adverse reaction initially submitted by a consumer cannot be downgraded to  
427 a report of non-related adverse event if the contacted healthcare professional (nominated by the  
428 consumer for follow-up information) disagrees with the consumer’s suspicion (see [VI.A.2.1.1.](#)). In this  
429 situation, the opinions of both the consumer and the healthcare professional should be included in the  
430 ICSR. Guidance on the reporting of the medical confirmation of a case, provided in ICH-E2B(R2)  
431 guideline Section A.1.14 (“Was the case medically confirmed, if not initially from a healthcare  
432 professional?”), should be followed.

433 For solicited reports of suspected adverse reactions (see [VI.B.1.2.](#)), where the receiver disagrees with  
434 the reasonable possibility of causal relationship between the suspected medicinal product and the  
435 adverse reaction expressed by the primary source, the case should not be downgraded to a report of  
436 non-related adverse event. The opinions of both, the primary source and the receiver, should be  
437 recorded in the ICSR.

---

<sup>9</sup> See [Footnote 8.](#)

<sup>10</sup> There is no suspected adverse reaction.

<sup>11</sup> For further guidance on reporting of other duplicate ICSRs, refer to Section A.1.11 “Other case identifiers in previous transmission” of ICH-E2B(R2) guideline.

438 The same principle applies to the ICSR seriousness criterion, which should not be downgraded from  
439 serious to non-serious if the receiver disagrees with the seriousness reported by the primary source.

### 440 **VI.B.3. Follow-up of reports**

441 When first received, the information in suspected adverse reactions reports may be incomplete. These  
442 reports should be followed-up as necessary to obtain supplementary detailed information significant for  
443 the scientific evaluation of the cases. This is particularly relevant for monitored events of special  
444 interest, prospective reports of pregnancy, cases notifying the death of a patient, cases reporting new  
445 risks or changes in the known risks. This is in addition to any effort to collect missing minimum  
446 information (see [VI.B.2.](#)). Any attempt to obtain follow-up information should be documented.

447 Follow-up methods should be tailored towards optimising the collection of missing information. This  
448 should be done in ways that encourage the primary source to submit new information relevant for the  
449 scientific evaluation of a particular safety concern. The use of targeted specific forms in the local  
450 language should avoid requesting the primary source to repeat information already provided in the  
451 initial report and/or to complete extensive questionnaires, which could discourage future spontaneous  
452 reporting. Therefore, consideration should be given to pre-populating some data fields in those follow-  
453 up report forms to make their completion by the primary source easy.

454 When information is received directly from a consumer suggesting that an adverse reaction may have  
455 occurred, if the information is incomplete, attempts should be made to obtain consent to contact a  
456 nominated healthcare professional to obtain further follow-up information. When such a case, initially  
457 reported by a consumer, has been confirmed (totally or partially) by a healthcare professional, this  
458 information should be clearly highlighted in the ICSR<sup>12</sup>.

459 For suspected adverse reactions relating to biological medicinal products, the definite identification of  
460 the concerned product with regard to its manufacturing is of particular importance. Therefore, all  
461 appropriate measures should be taken to clearly identify the name of the product and the batch  
462 number. A business process map in relation to the mandatory follow-up of information for the  
463 identification of suspected biological medicinal products is presented in [VI.Appendix 1.](#)

464 For cases related to vaccines, the recommendations provided in the [Guideline on the conduct of  
465 Pharmacovigilance for Vaccines for Pre-and Post-exposure Prophylaxis against Infectious Diseases](#)<sup>13</sup>  
466 should also be followed as appropriate.

### 467 **VI.B.4. Data management**

468 Electronic data and paper reports of suspected adverse reactions should be stored and treated in the  
469 same way as other medical records with appropriate respect for confidentiality regarding patients' and  
470 reporters' identifiability and in accordance with local data privacy laws. Confidentiality of patients'  
471 records including personal identifiers, if provided, should always be maintained. Identifiable personal  
472 details of reporting healthcare professionals should be kept in confidence. With regards to patient's and  
473 reporter's identifiability, case report information should be transmitted between stakeholders  
474 (marketing authorisation holders or competent authorities) in accordance with local data privacy laws  
475 (see [VI.C.6.2.2.8.](#) for the processing of personal data in ICSRs in the EU).

476 In order to ensure pharmacovigilance data security and confidentiality, strict access controls should be  
477 applied to documents and to databases to authorised personnel only. This security extends to the

---

<sup>12</sup> For further guidance on reporting this information, refer to ICH-E2B(R2) guideline, Section A.1.14 ("Was the case medically confirmed, if not initially from a healthcare professional?").

<sup>13</sup> (Ref.: [EMA/CHMP/PhVWP/503449/2007](#))

478 complete data path. In this aspect, procedures should be implemented to ensure security and non-  
479 corruption of data during data transfer.

480 When transfer of pharmacovigilance data occurs within an organisation or between organisations  
481 having concluded contractual agreements, the mechanism should be such that there is confidence that  
482 all notifications are received; in that, a confirmation and/or reconciliation process should be  
483 undertaken.

484 Correct data entry, including the appropriate use of terminologies, should be verified by quality  
485 assurance auditing, either systematically or by regular random evaluation. Data entry staff should be  
486 instructed in the use of the terminologies, and their proficiency confirmed.

487 Data received from the primary source should be treated in an unbiased and unfiltered way and  
488 inferences as well as imputations should be avoided during data entry or electronic transmission. The  
489 reports should include the verbatim text as used by the primary source or an accurate translation of it.  
490 The original verbatim text should be coded using the appropriate terminology as described in [VI.B.8](#). In  
491 order to ensure consistency in the coding practices, it is recommended to use, where applicable, the  
492 translation of the terminology in the local language to code the verbatim text.

493 Electronic data storage should allow traceability (audit trail) of all data entered or modified, including  
494 dates and sources of received data, as well as dates and destinations of transmitted data.

495 A procedure should be in place to account for identification and management of duplicate cases at data  
496 entry and during the generation of aggregated reports (see [VI.C.6.2.4](#)).

#### 497 ***VI.B.5. Quality management***

498 Competent authorities and marketing authorisation holders should have a quality management system  
499 in place to ensure compliance with the necessary quality standards at every stage of case  
500 documentation, such as data collection, data transfer, data management, data coding, case validation,  
501 case evaluation, case follow-up, ICSR reporting and case archiving (see [VI.C.6.2.4](#) and [Module I](#)).  
502 Conformity of stored data with initial and follow-up reports should be verified by quality control  
503 procedures, which permit for the validation against the original data or images thereof. In this aspect,  
504 the source data (e.g., letters, emails, records of telephone calls that include details of an event) or an  
505 image of the source data should be easily accessible.

506 Clear written standard operating procedures should guarantee that the roles and responsibilities and  
507 the required tasks are clear to all parties involved and that there is provision for proper control and,  
508 when needed, change of the system. This is equally applicable to activities that are contracted out to  
509 third parties, whose procedures should be reviewed to verify that they are adequate and compliant  
510 with applicable requirements.

511 Staff directly performing pharmacovigilance activities, should be appropriately trained in applicable  
512 pharmacovigilance legislation and guidelines in addition to specific training in report processing  
513 activities for which they are responsible and/or undertake. Other personnel who may receive or  
514 process safety reports (e.g. clinical development, sales, medical information, legal, quality control)  
515 should be trained in adverse event collection and reporting in accordance with internal policies and  
516 procedures.

517 **VI.B.6. Special situations**

518 **VI.B.6.1. Use of a medicinal product during pregnancy or breastfeeding**

519 **a. Pregnancy**

520 Reports, where the embryo or foetus may have been exposed to medicinal products (either through  
521 maternal exposure or transmission of a medicinal product via semen following paternal exposure),  
522 should be followed-up in order to collect information on the outcome of the pregnancy and  
523 development of the child after birth. The recommendations provided in the **Guideline on the Exposure**  
524 **to Medicinal Products during Pregnancy: Need for Post-Authorisation Data**<sup>14</sup> should be considered as  
525 regard the monitoring, collection and reporting of information in these specific situations in order to  
526 facilitate the scientific evaluation. When an active substance (or one of its metabolites) has a long half-  
527 life, this should be taken into account when assessing the possibility of exposure of the embryo, if the  
528 medicinal product was taken before conception.

529 Not infrequently, pregnant women or healthcare professionals will contact either competent authorities  
530 or marketing authorisation holders to request information on the teratogenicity of a medicinal product  
531 and/or experience of use during pregnancy. Reasonable attempts should be made to obtain  
532 information on any possible medicinal product exposure to an embryo or foetus and to follow-up on the  
533 outcome of the pregnancy.

534 Reports of exposure to medicinal products during pregnancy should contain as many detailed elements  
535 as possible in order to assess the causal relationships between any reported adverse events and the  
536 exposure to the suspected medicinal product. In this context the use of standard structured  
537 questionnaires is recommended.

538 Individual cases with an abnormal outcome associated with a medicinal product following exposure  
539 during pregnancy are classified as serious reports and should be reported, in accordance with the  
540 requirements outlined in **VI.B.7**<sup>15</sup>.

541 This especially refers to:

- 542 • reports of congenital anomalies or developmental delay, in the foetus or the child;  
543 • reports of foetal death and spontaneous abortion; and  
544 • reports of suspected adverse reactions in the neonate that are classified as serious.

545 Other cases, such as reports of induced termination of pregnancy without information on congenital  
546 malformation, reports of pregnancy exposure without outcome data or reports which have a normal  
547 outcome, should not be reported since there is no suspected adverse reaction. These reports should  
548 however be collected and discussed in the periodic safety update reports (see **Module VII**).

549 However, in certain circumstances, reports of pregnancy exposure with no suspected reactions may  
550 necessitate to be reported. This may be a condition of the marketing authorisation or stipulated in the  
551 risk management plan; for example pregnancy exposure to medicinal products contraindicated in  
552 pregnancy or medicinal products with a special need for surveillance because of a high teratogenic  
553 potential (e.g. thalidomide, isotretinoin).

---

<sup>14</sup> (Ref.: [EMEA/CHMP/313666/2005](#))

<sup>15</sup> See [VI.C.6.2.3.1](#) for electronic reporting recommendations in the EU.



554 A signal of a possible teratogen effect (e.g. through a cluster of similar abnormal outcomes) should be  
555 notified immediately to the competent authorities in accordance with the recommendations presented  
556 in [VI.C.2.2.6](#).

#### 557 **b. Breastfeeding**

558 Suspected adverse reactions which occur in infants following exposure to a medicinal product from  
559 breast milk should be reported in accordance with the criteria outlined in [VI.B.7](#)<sup>16</sup>.

### 560 **VI.B.6.2. Use of a medicinal product in a paediatric or elderly population**

561 The collection of safety information in the paediatric or elderly population is important. Reasonable  
562 attempts should therefore be made to obtain and submit the age or age group of the patient when a  
563 case is reported by a healthcare professional, or consumer in order to be able to identify potential  
564 safety signals specific to a particular population.

565 As regards the paediatric population, the guidance published by the Agency<sup>17</sup> on the conduct of  
566 pharmacovigilance in this population should be followed.

### 567 **VI.B.6.3. Reports of overdose, abuse, off-label use, misuse, medication 568 error or occupational exposure**

569 For the purpose of this Module, medication error refers to any unintentional error in the prescribing,  
570 dispensing, or administration of a medicinal product while in the control of the healthcare professional,  
571 patient or consumer.

572 Reports of overdose, abuse, off-label use, misuse, medication error or occupational exposure with no  
573 associated adverse reaction should not be reported as ICSRs. They should be considered in periodic  
574 safety update reports as applicable. When those reports constitute safety issues impacting on the risk-  
575 benefit balance of the medicinal product, they should be notified to the competent authorities in  
576 accordance with the recommendations provided in [VI.C.2.2.6](#).

577 Reports associated with suspected adverse reactions should be subject to reporting in accordance with  
578 the criteria outlined in [VI.B.7](#) and with the electronic reporting requirements described in [VI.C.6.2.3.3](#).  
579 They should be routinely followed-up to ensure that the information is as complete as possible with  
580 regards to the symptoms, treatments, outcomes, context of occurrence (e.g., error in prescription,  
581 administration, dispensing, dosage, unauthorised indication or population, etc.).

### 582 **VI.B.6.4. Lack of therapeutic efficacy**

583 Reports of lack of therapeutic efficacy should be recorded and followed-up if incomplete. They should  
584 not normally be reported, but should be discussed in periodic safety update reports as applicable.  
585 However, in certain circumstances, reports of lack of therapeutic efficacy may require to be reported  
586 within a 15-day time frame (see [VI.C.6.2.3.4](#) as regards electronic reporting in the EU). Medicinal  
587 products used in critical conditions or for the treatment of life-threatening diseases, vaccines,  
588 contraceptives are examples of such cases. This applies unless the reporter has specifically stated that  
589 the outcome was due to disease progression and was not related to the medicinal product.

590 Clinical judgement should be used when considering if other cases of lack of therapeutic efficacy  
591 qualify for reporting. For example, an antibiotic used in a life-threatening situation where the medicinal

---

<sup>16</sup> See Footnote 15.

<sup>17</sup> Guideline on conduct of pharmacovigilance for medicines used by the paediatric population  
([EMA/CHMP/PhVWP/235910/2005- rev.1](#)).

592 product was not in fact appropriate for the infective agent should not be reported. However, a life-  
593 threatening infection, where the lack of therapeutic efficacy appears to be due to the development of a  
594 newly resistant strain of a bacterium previously regarded as susceptible, should be reported within 15  
595 days.

596 For vaccines, cases of lack of therapeutic efficacy should be reported, in particular with the view to  
597 highlight potential signals of reduced immunogenicity in a sub-group of vaccinees, waning immunity,  
598 or strain replacement. With regard to the latter, it is considered that spontaneously reported cases of  
599 lack of therapeutic efficacy by a healthcare professional may constitute a signal of strain replacement.  
600 Such a signal may need prompt action and further investigation through post-authorisation safety  
601 studies as appropriate. General guidance regarding the monitoring of vaccines failure, provided in the  
602 [Report of CIOMS/WHO Working Group on Vaccine Pharmacovigilance](#)<sup>18</sup>, may be followed.

### 603 **VI.B.7. Reporting of ICSRs**

604 Only valid ICSRs (see [VI.B.2.](#)) should be reported. The clock for the reporting of a valid ICSR starts as  
605 soon as the information containing the minimum reporting criteria has been brought to the attention of  
606 the national or regional pharmacovigilance centre of a competent authority or of any personnel of the  
607 marketing authorisation holder, including medical representatives and contractors. This date should be  
608 considered as day zero. **It is the first day when a receiver is informed of a valid ICSR, irrespective of  
609 whether the information is received during a weekend or public holiday. In practice this is the first  
610 business day the receiver becomes aware of the information.**

611 Where the marketing authorisation holder has set up contractual arrangements with a person or an  
612 organisation, explicit procedures and detailed agreements should exist between the marketing  
613 authorisation holder and the person/organisation to ensure that the marketing authorisation holder can  
614 comply with the reporting obligations. These procedures should in particular specify the processes for  
615 exchange of safety information, including timelines and regulatory reporting responsibilities and should  
616 avoid duplicate reporting to the competent authorities.

617 For ICSRs described in the scientific and medical literature (see [VI.B.1.1.2.](#)), the clock starts (day  
618 zero) with awareness of a publication containing the minimum information for reporting. Where  
619 contractual arrangements are made with a person/organisation to perform literature searches and/or  
620 report valid ICSRs, detailed agreements should exist to ensure that the marketing authorisation holder  
621 can comply with the reporting obligations.

622 When additional significant information is received for a previously reported case, the reporting time  
623 clock starts again for the submission of a follow-up report from the date of receipt of the relevant  
624 follow-up information. For the purpose of reporting, significant follow-up information corresponds to  
625 new medical or administrative information that could impact on the assessment or management of a  
626 case or could change its seriousness criteria; non-significant information includes updated comments  
627 on the case assessment or corrections of typographical errors in the previous case version. See also  
628 [VI.C.6.2.2.7.](#) as regards the distinction between significant and non-significant follow-up information.

#### 629 **VI.B.7.1. Reporting time frames**

630 In general, the reporting of serious valid ICSRs is required as soon as possible, but in no case later  
631 than 15 calendar days after initial receipt of the information by the national or regional  
632 pharmacovigilance centre of a competent authority or by any personnel of the marketing authorisation

---

<sup>18</sup> Council for International Organizations of Medical Sciences (CIOMS). Definition and application of terms of vaccine pharmacovigilance (report of CIOMS/WHO Working Group on Vaccine Pharmacovigilance). Genève: CIOMS; 2012.

633 holder, including medical representatives and contractors. This applies to initial and follow-up  
634 information. Where a case initially reported as serious becomes non-serious, based on new follow-up  
635 information, this information should still be reported within 15 days; the reporting time frame for non-  
636 serious reports should then be applied for the subsequent follow-up reports.

637 Information as regards the reporting time frame of non-serious valid ICSRs in the EU is provided in  
638 [VI.C.3.](#)

### 639 ***VI.B.8. Reporting modalities***

640 Taking into account the international dimension of adverse reactions reporting and the need to achieve  
641 harmonisation and high quality between all involved parties, ICSRs should be submitted electronically  
642 as structured data with the use of controlled vocabularies for the relevant data elements where  
643 applicable. In this aspect, with regard to the content and format of electronic ICSRs, competent  
644 authorities and marketing authorisation holders should adhere to the following internationally agreed  
645 ICH<sup>19</sup> guidelines and standards:

- 646 • ICH M1 terminology - Medical Dictionary for Regulatory Activities (MedDRA);
- 647 • MedDRA Term Selection: Points to Consider Document - The latest version of the ICH-endorsed  
648 Guide for MedDRA Users;
- 649 • ICH M2 EWG - Electronic Transmission of Individual Case Safety Reports Message Specification;
- 650 • ICH E2B(R2) - Maintenance of the ICH Guideline on Clinical Safety Data Management: Data  
651 Elements for Transmission of Individual Case Safety Reports;
- 652 • ICH E2B Implementation Working Group - Questions & Answers (R5) (March 3, 2005);

653 As technical standards evolve over time, the above referred documents may require revision and  
654 maintenance. In this context, the latest version of these documents should always be taken into  
655 account.

656 Information regarding EU specific reporting modalities is provided in [VI.C.4.](#)

---

<sup>19</sup> <http://www.ich.org/>

## 657 VI.C. Operation of the EU Network

658 Section C of this Module highlights the EU specific requirements, as defined in Directive 2001/83/EC  
659 and Regulation (EC) No 726/2004, in relation to the collection, management and reporting of reports  
660 of suspected adverse reactions (serious and non-serious) associated with medicinal products for  
661 human use authorised in the EU, independently of their condition of use. They are applicable to  
662 competent authorities in Member States and/or to marketing authorisation holders. Section C should  
663 be read in conjunction with the definitions and general principles detailed in [VI.A](#) and [VI.B](#) of this  
664 Module and with the requirements provided in Chapter IV, V and IX of the Commission Implementing  
665 Regulation (EU) No 520/2012 [IR].

### 666 ***VI.C.1. Interface with safety reporting rules for clinical trials and post*** 667 ***authorisation studies in the EU***

668 The pharmacovigilance rules laid down in Directive 2001/83/EC and Regulation (EC) No 726/2004 do  
669 not apply to investigational medicinal products and non-investigational medicinal products<sup>20</sup> used in  
670 clinical trials conducted in accordance with Directive 2001/20/EC<sup>21</sup>.

671 Post-authorisation safety or efficacy studies requested by competent authorities **in Member States** in  
672 accordance with Directive 2001/83/EC or Regulation (EC) No 726/2004, or conducted voluntarily by  
673 marketing authorisation holders, can either be clinical trials or non-interventional studies as shown in  
674 Figure VI.1. The safety reporting falls therefore either under the scope of Directive 2001/20/EC for any  
675 clinical trials or under the provisions set out in Directive 2001/83/EC and Regulation (EC) No 726/2004  
676 for any non-interventional studies. Suspected adverse reactions should not be reported under both  
677 regimes, that is Directive 2001/20/EC as well as Regulation (EC) No 726/2004 and Directive  
678 2001/83/EC as this creates duplicate reports.

679 Further guidance on post-authorisation safety studies is provided in **Module VIII**.

680 The different types of studies and clinical trials which can be conducted in the EU are illustrated in  
681 Figure VI.1. The safety reporting for clinical trials corresponding to Section A, B, C and D of Figure VI.1  
682 follows the requirements of Directive 2001/20/EC. The safety reporting for non-interventional studies  
683 corresponding to section E and F follows the requirements of Directive 2001/83/EC and Regulation  
684 (EC) No 726/2004. The reporting rules of solicited reports of suspected adverse reactions to the  
685 EudraVigilance database modules are dependent on the types of organised collection systems where  
686 they occurred; recommendations provided in [VI.C.6.2.1](#) should be followed.

---

<sup>20</sup> For guidance on these terms, see **The rules governing medicinal product in the European Union, Volume 10, Guidance applying to clinical Trials, Guidance on Investigational Medicinal Products and Non-Investigational Medicinal Products (NIMPs) (Ares(2011)300458 - 18/03/2011)**.

<sup>21</sup> See [DIR Art 3(3), Art 107(1) third subparagraph].



719 Where an untoward and unintended response originating from a clinical trial conducted in accordance  
720 with Directive 2001/20/EC, is suspected to be related only to a non-investigational medicinal product  
721 (or another medicinal product, which is not part of the clinical trial protocol) and does not result from a  
722 possible interaction with the investigational medicinal product, it does not follow the expedited  
723 reporting requirements of Directive 2001/20/EC, which apply only to the investigational medicinal  
724 product. The investigator or the sponsor is encouraged to report the case to the competent authority in  
725 the Member State where the reaction occurred or to the marketing authorisation holder of the  
726 suspected medicinal product, but not to both to avoid duplicate reporting<sup>22</sup>. Where made aware of such  
727 case, the competent authority or the marketing authorisation holder should apply the reporting  
728 requirements described in [VI.C.3](#), [VI.C.4](#) and [VI.C.6](#). As regards electronic reporting, the  
729 recommendations detailed in [VI.C.6.2.3.7](#) should be followed.

## 730 **VI.C.1.2. Interface with post-authorisation studies**

731 In the context of this module, post-authorisation studies are organised data collection systems which  
732 do not fall under the scope of the clinical trials Directive 2001/20/EC.

733 They include non-interventional post-authorisation studies, compassionate use, named patient use,  
734 other patient support and disease management programmes, registries, surveys of patients or  
735 healthcare providers, and information gathering on efficacy or patient compliance. **They may involve  
736 the receipt of information on adverse events.**

737 Competent authorities in Member States and marketing authorisation holders should have in place a  
738 system to collect full and comprehensive case information **on adverse events that are actively sought  
739 in post-authorisation studies** and to evaluate that information in order to determine whether the  
740 collected adverse events are possibly related to the studied (or supplied) medicinal product and should  
741 be classified and processed as ICSRs of suspected adverse reactions.

742 Different methods may be applied for assessing the causal role of a medicinal product on the reported  
743 adverse event (e.g. [WHO-UMC system for standardised case causality assessment](#)). In this situation,  
744 the levels of causality, which correspond to a reasonable possibility of causal relationship, should be  
745 established in advance in order to determine when an adverse event is considered as an adverse  
746 reaction.

747 Only valid ICSRs (see [VI.B.2.](#)) of adverse reactions, which are suspected to be related to the studied  
748 (or supplied) medicinal product by the primary source or the receiver of the case, should be reported.  
749 They should be considered as solicited reports (with the exception of certain reports from  
750 compassionate use or named patient use (see [VI.C.1.2.2.](#))) and reported by marketing authorisation  
751 holders or competent authorities in Member States in accordance with the requirements provided in  
752 [VI.C.3.](#), [VI.C.4.](#) and [VI.C.6.](#) Other reports of adverse events should only be included in the study  
753 report, where applicable.

754 Electronic reporting recommendations for cases originating in post-authorisation studies are detailed in  
755 [VI.C.6.2.3.7](#).

756 It may happen that reports of adverse reactions are only suspected to be related to other medicinal  
757 products which are not subject to the scope of the post-authorisation study. If there is no interaction  
758 with the studied (or supplied) medicinal product, these reports should be notified by the primary  
759 source, to the competent authority in the Member State where the reaction occurred or to the

---

<sup>22</sup> See The rules governing medicinal product in the European Union, Volume 10, [Detailed guidance on the collection, verification and presentation of adverse event/reaction reports arising from clinical trials on medicinal products for human use \('CT-3'\), \(2011/C 172/01\)](#).

760 marketing authorisation holder of the suspected medicinal product, but not to both to avoid duplicate  
761 reporting. Where made aware of such case, the concerned competent authorities or marketing  
762 authorisation holders should apply the reporting requirements described in [VI.C.3](#) and [VI.C.4](#) while  
763 respecting the electronic reporting recommendations detailed in [VI.C.6.2.3.7](#).

764 Further guidance on post-authorisation studies conducted by marketing authorisation holders is  
765 provided in [VI.C.2.2.2](#).

766 The requirements provided in this Module do not apply to academic sponsors, who should follow local  
767 requirements as regards the reporting of cases of suspected adverse reactions to the competent  
768 authority in the Member State where the reaction occurred. However, where a study is directly  
769 financed, initiated, managed (fully or partially), or where the its design is influenced by a marketing  
770 authorisation holder (voluntarily or pursuant to obligations imposed in accordance with Articles 21a or  
771 22a of Directive 2001/83/EC), the marketing authorisation holder should be considered as sponsor. In  
772 this context, the marketing authorisation holder should fulfil the reporting requirements detailed in this  
773 Module.

#### 774 **VI.C.1.2.1. Non-interventional studies**

775 Non-interventional studies should be distinguished between those with primary data collection directly  
776 from healthcare professionals or consumers, and healthcare professionals, and study designs which are  
777 based on secondary use of data such as studies based on medical chart reviews or electronic  
778 healthcare records, systematic reviews or meta-analyses.

- 779 • For non-interventional studies with primary data collection directly from healthcare professionals  
780 or consumers, non-academic sponsors should specify in the protocol any adverse events (serious  
781 or non-serious) to be actively sought and reported by healthcare professionals or consumers in the  
782 course of the study patients and healthcare professionals should be considered as organised data  
783 collection systems where adverse events are actively sought. Death and fatal outcomes are events  
784 which need to be actively collected by sponsors unless they are presented in the protocol as  
785 adverse events that will not be actively sought. The justification for this exemption should always  
786 be provided, for example because they represent outcomes of the study (efficacy end point),  
787 because patients included in the study have a disease with high mortality, or because occurrence  
788 of death has no relation to the objective of the study (such as in a drug utilisation study). For  
789 adverse events actively sought according to the protocol, only valid ICSRs (see [VI.B.2](#)) of adverse  
790 reactions suspected to be related to the studied medicinal product should be reported (as solicited  
791 reports) by the sponsor to the competent authorities. With regards to the electronic reporting of  
792 ICSRs, the recommendations provided in [VI.C.6.2.3.7](#) should be followed. All other serious and  
793 non-serious reports of adverse events, which are not actively sought according to the protocol,  
794 should only be summarised in the interim or final study report; they should not be reported as  
795 ICSRs to the competent authorities. Only reports of adverse reactions suspected to be related to  
796 the studied medicinal product should be reported. Reports of adverse events should only be  
797 summarised in the study report, where applicable.
- 798 • For non-interventional study designs which are based on secondary use of data, the reporting of  
799 suspected adverse reactions reporting as ICSRs is not required. Reports of adverse  
800 events/reactions should only be summarised in the interim or final study report, where applicable.
- 801 • In case of doubt, the reporting requirement should be clarified with the concerned competent  
802 authorities in Member States.

- 803 • With regard the reporting of cases of suspected adverse reactions to local ethics committees and  
804 investigators, the national legislation should be followed as applicable.

#### 805 **VI.C.1.2.2. Compassionate use, named patient use**

806 Where an organisation<sup>23</sup> or a healthcare professional, supplying a medicinal product under  
807 compassionate use or named patient use (see [VI.A.2.2.](#) for definitions), is notified or becomes aware  
808 of an adverse event, it should be managed as followed depending on the requirements in the  
809 concerned Member State:

- 810 • For compassionate and named patient uses where adverse events are actively sought, only reports  
811 of adverse reactions suspected to be related to the supplied medicinal product should be reported.  
812 They should be considered as solicited reports.
- 813 • For compassionate and named patient uses where the reporting of adverse events is not solicited,  
814 any notified noxious or unintended response to the supplied medicinal product should be  
815 considered as a spontaneous report of suspected adverse reaction by the receiver of the case.

#### 816 **VI.C.2. Collection of reports**

##### 817 **VI.C.2.1. Member States responsibilities**

818 Each Member State shall have in place a system for the collection and recording of unsolicited and  
819 solicited reports of suspected adverse reactions that occur in its territory and which are brought to its  
820 attention by healthcare professionals, consumers, or marketing authorisation holders<sup>24</sup> [DIR Art 101(1)  
821 and 107a(1)]. In this context, competent authorities in Member States shall establish procedures for  
822 collecting and recording all reports of suspected adverse reactions that occur in their territory [IR Art  
823 15 (2)]. The general principles detailed in [VI.B.](#), together with the reporting modalities presented in  
824 [VI.C.3.](#), [VI.C.4](#) and [VI.C.6](#) should be applied to those reports. Pharmacovigilance data and documents  
825 relating to individual authorised medicinal products shall be retained as long as the product is  
826 authorised and for at least 10 years after the marketing authorisation has expired. However, the  
827 documents shall be retained for a longer period where Union law or national law so requires [IR Art 16  
828 (2)].

829 Each Member State shall take all appropriate measures to encourage healthcare professionals and  
830 consumers in their territory to report suspected adverse reactions to their competent authority. In  
831 addition, the competent authority in a Member State may impose specific obligations on healthcare  
832 professionals. To this end, competent authorities in Member States shall facilitate in their territory the  
833 reporting of suspected adverse reactions by means of alternative straightforward reporting systems,  
834 accessible to healthcare professionals and consumers, in addition to web-based formats [DIR Art 102].  
835 Information on the different ways of reporting suspected adverse reactions related to medicinal  
836 products, shall be made publicly available including by means of national medicines web-based portals  
837 [DIR 106(e)]. To increase awareness of the reporting systems, organisations representing consumers  
838 and healthcare professionals may be involved as appropriate [DIR Art 102].

839 Standard web-based structured forms for the reporting of suspected adverse reactions by healthcare  
840 professionals and consumers shall be developed by the Agency in collaboration with Member States in  
841 order to collect across the EU harmonised information relevant for the evaluation of suspected adverse  
842 reactions, including errors associated with the use of medicinal products [REG Art 25]. In this context,

---

<sup>23</sup> E.g. sponsor, applicant, marketing authorisation holder, hospital or wholesaler.

<sup>24</sup> Marketing authorisation holders shall report ICSRs to the competent authorities in Member States in accordance with the transitional provisions set out in Article 2(4) and Article 2(5) of Directive 2010/84/EU and further detailed in [VI.C.4.1.](#)



843 core data fields for reporting will be made available by the Agency to the competent authorities in  
844 Member States for use in their national reporting systems as applicable.

845 The reports of suspected adverse reactions received from healthcare professionals and consumers  
846 should be acknowledged where appropriate and further information should be provided to the reporters  
847 as requested and when available.

848 For reports submitted by a marketing authorisation holder, Member States on whose territory the  
849 suspected adverse reaction occurred may involve the marketing authorisation holder in the follow-up  
850 of the reports [DIR Art 107a(2)].

851 Each Member State shall ensure that the competent authority responsible for medicinal products within  
852 that Member State is informed of any suspected adverse reaction, brought to the attention of any  
853 other authority, body, institution or organisation responsible for patient safety within that Member  
854 State, and that valid ICSRs are made available to the EudraVigilance database. Therefore, where  
855 reports of suspected adverse reactions are sent directly to other authorities, bodies, organisations  
856 and/or institutions within a Member State, the competent authority in that Member State shall have  
857 data exchange agreements in place so that these reports are brought to its attention and are made  
858 available to EudraVigilance in a timely manner[DIR Art 107a(5)]. This applies as well to reports of  
859 suspected adverse reactions arising from an error associated with the use of a medicinal product.  
860 Those error reports of suspected adverse reactions for which a competent authority in a Member  
861 State is made aware of, including those received from the EudraVigilance database in accordance with  
862 Article 24(4) of Regulation (EC) No 726/2004, shall also be brought to the attention of other  
863 authorities, bodies, organisations and/or institutions responsible for patient safety within that Member  
864 State [DIR Art 107a(5)].

865 Unless there are justifiable grounds resulting from pharmacovigilance activities, individual Member  
866 States shall not impose any additional obligations on marketing authorisation holders for the reporting  
867 of suspected adverse reactions [DIR Art 107a(6)].

### 868 **VI.C.2.2. Marketing authorisation holders responsibilities**

869 Each marketing authorisation holder shall have in place a system for the collection and recording of all  
870 reports of suspected adverse reactions which are brought to its attention, whether reported  
871 spontaneously by healthcare professionals or consumers or occurring in the context of a post-  
872 authorisation study [DIR Art 104(1), Art 107(1)]. Marketing authorisation holders shall not refuse to  
873 consider reports of suspected adverse reactions received electronically or by any other  
874 appropriate means from patients and healthcare professionals [Art 107(2)]. All those reports shall  
875 be accessible at a single point within the Union [Dir Art 107(1)].

876 Marketing authorisation holders shall establish mechanisms enabling the traceability and follow-up of  
877 adverse reaction reports while complying with the data protection legislation [IR Art 12 (1)].  
878 Pharmacovigilance data and documents relating to individual authorised medicinal products shall be  
879 retained as long as the product is authorised and for at least 10 years after the marketing  
880 authorisation has ceased to exist. However, the documents shall be retained for a longer period where  
881 Union law or national law so requires [IR Art 12 (2)].

882 With regard to the collection and recording of reports of suspected adverse reactions, marketing  
883 authorisation holders responsibilities apply to reports related to medicinal products (see [VI.A.2.2.](#)) for  
884 which ownership cannot be excluded on the basis of one the following criteria: medicinal product  
885 name, active substance name, pharmaceutical form, batch number or route of administration.  
886 Exclusion based on the primary source country or country of origin of the adverse reaction is possible if

887 the marketing authorisation holder can demonstrate that the suspected medicinal product has never  
888 been supplied or placed on the market in that territory or that the product is not a travel medicine  
889 (e.g., anti-malarial medicinal product).

890 The marketing authorisation holder shall ensure that any information on adverse reactions, suspected  
891 to be related to at least one of the active substances of its medicinal products authorised in the EU, is  
892 brought to its attention by any company outside the EU belonging to the same mother company (or  
893 group of companies)<sup>25</sup>. The same applies to the marketing authorisation holder when having  
894 concluded a commercial agreement with a company outside the EU for one of its medicinal product  
895 authorised in the EU. The clock for reporting (see [VI.B.7.](#)) starts when a valid ICSR is first received by  
896 one of these companies outside the EU.

897 In addition to the requirements presented in this chapter, the general principles detailed in Section  
898 [VI.B.](#), together with the reporting modalities presented in [VI.C.3.](#), [VI.C.4.](#) and [VI.C.6.](#) should be  
899 applied by marketing authorisation holders to all reports of suspected adverse reactions.

#### 900 ***VI.C.2.2.1. Spontaneous reports***

901 Marketing authorisation holders shall record all reports of suspected adverse reactions originating from  
902 within or outside the EU, which are brought to their attention spontaneously by healthcare  
903 professionals, or consumers. This includes reports of suspected adverse reactions received  
904 electronically or by any other appropriate means [DIR Art 107(1), Art 107(2)]. In this context,  
905 marketing authorisation holders may consider utilising their websites to facilitate the collection of  
906 reports of suspected adverse reactions by providing adverse reactions forms for reporting, or  
907 appropriate contact details for direct communication (see [VI.B.1.1.4.](#)).

#### 908 ***VI.C.2.2.2. Solicited reports***

909 In accordance with Art 107(1) of Directive 2001/83/EC, marketing authorisation holders shall record all  
910 reports of suspected adverse reactions originating from within or outside the EU, which occur in post-  
911 authorisation studies, initiated, managed, or financed by them<sup>26</sup>. General guidance on post-  
912 authorisation studies is provided in [VI.C.1.2.](#) Electronic reporting recommendations for cases  
913 originating in post-authorisation studies are detailed in [VI.C.6.2.3.7.](#)

914 For ~~post-authorisation studies-solicited reports~~, marketing authorisation holders should have  
915 mechanisms in place to collect full and comprehensive case information and to evaluate that  
916 information, in order to allow meaningful assessment of individual cases and reporting of valid ICSRs  
917 (see [VI.B.2.](#)) related to the studied (or supplied) medicinal product. Marketing authorisation holders  
918 should therefore exercise due diligence in establishing such system, in following-up those reports (see  
919 [VI.B.3.](#)) and in seeking the view of the primary source as regard the causal role of the studied (or  
920 supplied) medicinal product on the notified adverse event. Where this opinion is missing, the  
921 marketing authorisation holder should exercise its own judgement based on the information available  
922 in order to decide whether the report is a valid ICSR, which should be reported to the competent  
923 authorities. This does not apply to study designs based on secondary use of data for which reporting of  
924 ICSRs is not required (see [VI.C.1.2.1.](#)).

925 Safety data to be presented in the relevant sections of the periodic safety update report of the  
926 authorised medicinal product are detailed in [Module VII](#).

---

<sup>25</sup> As outlined in the Commission communication on the Community marketing authorization procedures for medicinal products ([98/C 229/03](#)).

<sup>26</sup> This does not concern donation of a medicinal product for research purpose if the marketing authorisation holder has no influence on the study.

927 **VI.C.2.2.3. Case reports published in the scientific and medical literature**

928 General principles in relation to the monitoring for individual cases of suspected adverse reactions  
929 described in the scientific and medical literature are provided in [VI.B.1.1.2.](#) As regards the screening  
930 of the scientific and medical literature, the requirements provided in this Module are part of the wider  
931 literature searches which need to be conducted for periodic safety update reports (see [Module VII](#)).

932 In accordance with Article 107(3) of Directive 2001/83/EC, in order to avoid the reporting of duplicate  
933 ICSRs, marketing authorisation holders shall only report those ICSRs described in the scientific and  
934 medical literature which is not reviewed by the Agency, for all medicinal products containing active  
935 substances which are not included in the list monitored by the Agency pursuant to Article 27 of  
936 Regulation (EC) No 726/2004. Until such lists of scientific and medical literature and active substance  
937 names are published by the Agency, marketing authorisation holders should monitor all the active  
938 substances for which they hold a marketing authorisation in the EU by accessing a widely used  
939 systematic literature review and reference database, in line with the principles detailed in [VI.B.1.1.2.](#)  
940 and in [VI. Appendix 2](#)

941 Articles can be excluded from the reporting of ICSRs by the marketing authorisation holder if another  
942 company's branded medicinal product is the suspected medicinal product. In the absence of a specified  
943 medicinal product source and/or invented name, ownership of the medicinal product should be  
944 assumed for articles about an active substance, unless alternative reasons for exclusion detailed  
945 hereafter apply.

- 946
- 947 • Where ownership of the medicinal product by the marketing authorisation holder can be excluded  
948 on the basis of the criteria detailed in [VI.C.2.2.](#);
  - 949 • For individual case safety reports identified in the scientific and medical literature that originate in  
950 a country where a company holds a marketing authorisation but has never commercialised the  
951 medicinal product;
  - 952 • For literature ICSRs which are based on an analysis from a competent authority database within  
953 the EU. The reporting requirements remain for those ICSRs which are based on the analysis from a  
954 competent authority database outside the EU;
  - 955 • For literature articles, which present data analyses from publicly available databases or, which  
956 summarise results from post-authorisation studies (see [VI.C.1.2.](#)). This type of literature article  
957 describes adverse reactions, which occur in a group of patients with a designated medicinal  
958 product with the aim of identifying or quantifying a safety hazard related to a medicinal product,  
959 and aggregated data on patients are often presented in tables or line listings. The main objective  
960 of those studies is to detect/evaluate specific risks that could affect the overall risk-benefit balance  
961 of a medicinal product.

961 New and significant safety findings presented in these articles, for which reporting is not required,  
962 should however be discussed in the relevant sections of the concerned periodic safety update report  
963 (see [Module VII](#)) and analysed as regards their overall impact on the medicinal product risk-benefit  
964 profile. In addition, any new safety information, which may impact on the risk-benefit profile of a  
965 medicinal product, should be notified immediately to the competent authorities in Member States  
966 where the medicinal product is authorised and to the Agency in accordance with the recommendations  
967 provided in [VI.C.2.2.6.](#)

968 A detailed guidance on the monitoring of the scientific and medical literature has been developed in  
969 accordance with Article 27(3) of Regulation (EC) No 726/2004; it is included in [VI. Appendix 2.](#)

970 The electronic reporting recommendations regarding suspected adverse reactions reports published in  
971 the scientific and medical literature are provided in [VI.C.6.2.3.2](#).

972 ***VI.C.2.2.4. Suspected adverse reactions related to quality defect or falsified medicinal***  
973 ***products***

974 When a report of suspected adverse reactions is associated with a suspected or confirmed falsified  
975 medicinal product or quality defect of a medicinal product, a valid ICSR should be reported. The  
976 seriousness of the ICSR is linked to the seriousness of the reported suspected adverse reactions in  
977 accordance with the definitions provided in [VI.A.2.4](#). Electronic reporting recommendations provided  
978 in [VI.C.6.2.3.5](#) should be followed.

979 In addition in order to protect public health, it may become necessary to implement urgent measures  
980 such as the recall of one or more defective batch(es) of a medicinal product from the market.  
981 Therefore, marketing authorisation holders should have a system in place to ensure that reports of  
982 suspected adverse reactions related to falsified medicinal products or to quality defects of a medicinal  
983 products are investigated in a timely fashion and that confirmed quality defects are notified separately  
984 to the manufacturer and to competent authorities in accordance with the provisions described in Article  
985 13 of [Directive 2003/94/EC](#).

986 ***VI.C.2.2.5. Suspected transmission via a medicinal product of an infectious agent***

987 For the purposes of reporting, any suspected transmission of an infectious agent via a medicinal  
988 product should be considered as a serious adverse reaction and such cases should be reported within  
989 15 days in accordance with the requirements outlined in [VI.C.4](#)<sup>27</sup>. If no other criterion is applicable,  
990 the seriousness of this ICSR should be considered as important medical event (see [VI.A.2.4](#)). This also  
991 applies to vaccines. Electronic reporting recommendations provided in [VI.C.6.2.3.6](#) should be followed.

992 In the case of medicinal products derived from human blood or human plasma, haemovigilance  
993 procedures may also apply in accordance with [Directive 2002/98/EC](#). Therefore the marketing  
994 authorisation holder should have a system in place to communicate suspected transmission via a  
995 medicinal product of an infectious agent to the manufacturer, the relevant blood establishment(s) and  
996 national competent authorities in Member States.

997 Any organism, virus or infectious particle (e.g. prion protein transmitting Transmissible Spongiform  
998 Encephalopathy), pathogenic or non-pathogenic, is considered an infectious agent.

999 A transmission of an infectious agent may be suspected from clinical signs or symptoms, or laboratory  
1000 findings indicating an infection in a patient exposed to a medicinal product.

1001 Emphasis should be on the detection of infections/infectious agents known to be potentially  
1002 transmitted via a medicinal product, but the occurrence of unknown agents should also always be  
1003 considered.

1004 In the context of evaluating a suspected transmission of an infectious agent via a medicinal product,  
1005 care should be taken to discriminate, whenever possible, between the cause (e.g., injection/  
1006 administration) and the source (e.g., contamination) of the infection and the clinical conditions of the  
1007 patient at the time of the infection (immuno-suppressed /vaccinee).

1008 Confirmation of contamination (including inadequate inactivation/attenuation of infectious agents as  
1009 active substances) of the concerned medicinal product increases the evidence for transmission of an

---

<sup>27</sup> See [VI.C.6.2.3.6](#) for electronic reporting recommendations.

1010 infectious agent and may therefore be suggestive of a quality defect for which the procedures detailed  
1011 in [VI.C.2.2.4](#) should be applied.

1012 Medicinal products should comply with the recommendations provided in the Note for Guidance on  
1013 Minimising the Risk of Transmitting Animal Spongiform Encephalopathy Agents via Human and  
1014 Veterinary Products<sup>28</sup>. For advanced therapy medicinal products, Article 14(5) of [Regulation \(EC\) No  
1015 1394/2007](#) and the [Guideline on Safety and Efficacy Follow-up - Risk Management of Advanced  
1016 Therapy Medicinal Products](#)<sup>29</sup>, should also be followed as appropriate.

#### 1017 **VI.C.2.2.6. Emerging safety issues**

1018 Events may occur, which do not fall within the definition of reportable valid ICSRs, and thus are not  
1019 subject to the reporting requirements, even though they may lead to changes in the known risk-benefit  
1020 balance of a medicinal product and/or impact on public health. Examples include:

- 1021 • major safety findings from a newly completed non-clinical study;
- 1022 • major safety concerns identified in the course of a non-interventional post-authorisation study or of  
1023 a clinical trial;
- 1024 • signal of a possible teratogen effect or of significant hazard to public health;
- 1025 • safety issues published in the scientific and medical literature;
- 1026 • safety issues arising from the signal detection activity (see [Module IX](#)) or emerging from a new  
1027 ICSR and which impact on the risk-benefit balance of the medicinal product and/or have  
1028 implications for public health;
- 1029 • safety issues related to the use outside the terms of the marketing authorisation;
- 1030 • safety issues due to misinformation in the product information;
- 1031 • marketing authorisation withdrawal, non-renewal, revocation or suspension outside the EU for  
1032 safety-related reasons;
- 1033 • urgent safety restrictions outside the EU;
- 1034 • safety issues in relation to the supply of raw material;
- 1035 • lack of supply of medicines.

1036 These events/observations, which may affect the risk-benefit balance of a medicinal product, are not to  
1037 be submitted as ICSRs. They should be notified as Emerging Safety Issues in writing to the competent  
1038 authorities in Member States where the medicinal product is authorised and to the Agency via email  
1039 ([P-PV-emerging-safety-issue@ema.europa.eu](mailto:P-PV-emerging-safety-issue@ema.europa.eu)); this should be done immediately when becoming  
1040 aware of them. The document should indicate the points of concern and the actions proposed in  
1041 relation to the marketing application/authorisation for the concerned medicinal product. Those safety  
1042 issues should also be analysed in the relevant sections of the periodic safety update report of the  
1043 authorised medicinal product.

#### 1044 **VI.C.2.2.7. Period between the submission of the marketing authorisation application and 1045 the granting of the marketing authorisation**

1046 In the period between the submission of the marketing authorisation application and the granting of  
1047 the marketing authorisation, information (quality, non-clinical, clinical) that could impact on the risk-

---

<sup>28</sup> Latest revision. (Ref.: [EMA/410/01](#)).

<sup>29</sup> (Ref.: [EMEA/149995/2008](#))

1048 benefit balance of the medicinal product under evaluation may become available to the applicant<sup>30</sup>. It  
1049 is the responsibility of the applicant to ensure that this information is immediately submitted in  
1050 accordance with the modalities described in [VI.C.2.2.6](#), to the competent authorities in the Member  
1051 States where the application is under assessment (including Reference Member State and all  
1052 concerned Member States for products assessed under the mutual recognition or decentralised  
1053 procedures) and to the Agency. For applications under the centralised procedure, the information  
1054 should also be provided to the (Co-) Rapporteur.

1055 In the situation where a medicinal product application is under evaluation in the EU while it has already  
1056 been authorised in a third country, valid ICSRs from outside the EU, originating from unsolicited  
1057 reports (see [VI.B.1.1.](#)) or solicited reports (see [VI.B.1.2.](#)), should be reported in accordance with the  
1058 requirements provided in [VI.C.3.](#), [VI.C.4.](#) and [VI.C.6.](#)

#### 1059 ***VI.C.2.2.8. Period after suspension, revocation or withdrawal of marketing authorisation***

1060 The marketing authorisation holder shall continue to collect any reports of suspected adverse reactions  
1061 related to the concerned medicinal product following the suspension of a marketing authorisation. The  
1062 reporting requirements outlined in [VI.C.4.](#) remain.

1063 Where a marketing authorisation is withdrawn or revoked, the former marketing authorisation holder is  
1064 encouraged to continue to collect spontaneous reports of suspected adverse reactions originating  
1065 within the EU to for example facilitate the review of delayed onset adverse reactions or of  
1066 retrospectively notified cases.

#### 1067 ***VI.C.2.2.9. Period during a public health emergency***

1068 A public health emergency is a public health threat duly recognised either by the World Health  
1069 Organization (WHO) or the Community in the framework of [Decision No. 2119/98/EC](#) of the European  
1070 Parliament and of the Council. In the event of a public health emergency, regular reporting  
1071 requirements may be amended. Such arrangements will be considered on a case-by-case basis and will  
1072 be appropriately notified on the Agency website.

#### 1073 ***VI.C.2.2.10. Reports from class action lawsuits***

1074 Stimulated reports arising from class action lawsuits should be managed as spontaneous reports. Valid  
1075 ICSRs should describe adverse reactions related to the concerned medicinal product. They should be  
1076 reported in accordance with the time frames and modalities described in [VI.C.3.](#), [VI.C.4.](#) and [VI.C.6.](#)

1077 Where large batches of potential ICSRs are received, marketing authorisation holders may request, in  
1078 exceptional circumstances, for an exemption in order to submit serious cases of suspected adverse  
1079 reactions within 30 days from their date of receipt instead of 15 days. The 90 days reporting time  
1080 frame for non-serious ICSRs remains unchanged. It will be possible to apply for this exemption only  
1081 once the functionalities of the EudraVigilance database specified in Article 24(2) of Regulation (EC) No  
1082 726/2004 are established. The request should be made to the Agency Pharmacovigilance Department.

#### 1083 ***VI.C.2.2.11. Reports from patient support programmes and market research programmes***

1084 A patient support programme is an organised system where a marketing authorisation holder receives  
1085 and collects information relating to the use of its medicinal products. Examples are post-authorisation

---

<sup>30</sup> See also Chapter 1, Section 5.1.1 of [Volume 2A \(Notice to Applicants\) of The Rules Governing Medicinal Products in the European Union](#).

1086 patient support and disease management programmes, surveys of patients and healthcare providers,  
1087 information gathering on patient compliance, or compensation/re-imburement schemes.

1088 A market research programme refers to the systematic collection, recording and analysis by a  
1089 marketing authorisation holder of data and findings about its medicinal products, relevant for  
1090 marketing and business development.

1091 Safety reports originating from those programmes should be considered as solicited reports. Marketing  
1092 authorisation holders should have the same mechanisms in place as for all other solicited reports (see  
1093 [VI.C.2.2.2.](#)) to manage that information and report valid cases of adverse reactions, which are  
1094 suspected to be related to the concerned medicinal product.

1095 Valid ICSRs should be reported as solicited in accordance with the electronic reporting requirements  
1096 provided in [VI.C.6.2.3.7.](#)

### 1097 ***VI.C.3. Reporting time frames***

1098 The general rules in relation to the reporting of initial and follow-up reports, including those for  
1099 defining the clock start are detailed in [VI.B.7.](#)

1100 According to Articles 107(3) and 107a(4) of Directive 2001/83/EC,

- 1101 • serious valid ICSRs shall be reported by competent authorities in Member States or by marketing  
1102 authorisation holders within 15 days from the date of receipt of the reports;
- 1103 • non-serious valid ICSRs shall be reported by competent authorities in Member States or by  
1104 marketing authorisation holders within 90 days from the date of receipt of the reports.

1105 This should be done in accordance with the reporting modalities detailed in [VI.C.4.](#)

### 1106 ***VI.C.4. Reporting modalities***

1107 In addition to the recommendations provided in [VI.B.8.](#), competent authorities in Member States and  
1108 marketing authorisation holders shall use the formats, standards and terminologies for the electronic  
1109 transmission of suspected adverse reactions as referred to in Chapter IV of the Commission  
1110 Implementing Regulation (EU) No 520/2012. ICSRs shall be used for reporting to the Eudravigilance  
1111 database suspected adverse reactions to a medicinal product that occur in a single patient at a specific  
1112 point in time [IR Art 27]. Competent authorities in Member States and marketing authorisation holders  
1113 shall also ensure that all reported electronic ICSRs are well documented and as complete as possible in  
1114 accordance with the requirements provided in [IR Art 28].

1115 The time frames for reporting serious and non-serious valid ICSRs are provided in [VI.C.3.](#) The  
1116 recommendations provided in [VI.C.6.](#) should be adhered to as regards the electronic exchange of  
1117 pharmacovigilance information between competent authorities in Member States, marketing  
1118 authorisation holders and the Agency.

1119 ICSRs reported electronically to the EudraVigilance database will be made accessible to stakeholders  
1120 such as competent authorities, healthcare professionals, consumers, as well as marketing authorisation  
1121 holders and research organisations in accordance with Article 24(2) of Regulation (EC) No 726/2004  
1122 and the EudraVigilance access policy<sup>31</sup>. This policy defines the overall principles of the provision of  
1123 access to EudraVigilance data in line with the current legal framework, while guaranteeing personal  
1124 data protection. As detailed in the EudraVigilance access policy, a selection of ICSRs could be

---

<sup>31</sup> EudraVigilance Access Policy for Medicines for Human Use ([EMA/759287/2009](#)).

1125 downloaded by marketing authorisation holders in ICH E2B format and in accordance with the ICH M2  
1126 message specifications, to facilitate their pharmacovigilance activities.

#### 1127 **VI.C.4.1. Interim arrangements**

1128 In accordance with the provisions set out in Article 2(4), Article 2(5) and Article 2(6) of Directive  
1129 2010/84/EU, until the Agency can ensure the functionalities of the EudraVigilance database as  
1130 specified in Article 24(2) of Regulation (EC) No 726/2004, the following reporting requirements shall  
1131 apply to valid unsolicited and solicited ICSRs reported by healthcare professionals and non-healthcare  
1132 professionals. This is independently of the condition of use of the suspected medicinal product and of  
1133 the expectedness of the adverse reaction.

##### 1134 **a. Serious ICSRs**

- 1135 • Marketing authorisation holders shall report all serious ICSRs that occur in the EU to the competent  
1136 authority of the Member State on whose territory the suspected adverse reactions occurred.
- 1137 • Marketing authorisation holders shall report to the EudraVigilance database all serious ICSRs that  
1138 occur outside the EU, including those received from competent authorities. If required by Member  
1139 States, those reports shall also be submitted to the competent authorities in the Member States in  
1140 which the medicinal product is authorised.
- 1141 • Competent authorities in Member States shall ensure that all serious ICSRs that occur in their  
1142 territory and that are reported to them, including those received from marketing authorisation  
1143 holders, are made available to the EudraVigilance database. Competent authorities in Member  
1144 States should also make available, to the marketing authorisation holders of the suspected  
1145 medicinal products, all serious ICSRs reported directly to them.

##### 1146 **b. Non-Serious ICSRs**

- 1147 • If required by Member States, marketing authorisation holders shall report all non-serious ICSRs  
1148 that occur in the EU to the competent authority of the Member State on whose territory the  
1149 suspected adverse reactions occurred.

1150 Overviews of the reporting requirements of serious and non-serious reports during the interim period,  
1151 applicable to marketing authorisation holders or competent authorities in Member States, are  
1152 presented in [VI. Appendix 3.1](#), together with a detailed business process map.

1153 Member States reporting requirements for serious non-EU ICSRs and for non-serious EU ICSRs are also  
1154 included in this Appendix.

#### 1155 **VI.C.4.2. Final arrangements**

1156 Once the functionalities of the EudraVigilance database specified in Article 24(2) of Regulation (EC) No  
1157 726/2004 are established, the following requirements, detailed in Articles 107(3) and 107a(4) of  
1158 Directive 2001/83/EC, shall apply within 6 months of the announcement by the Agency to valid  
1159 unsolicited and solicited ICSRs reported by healthcare professionals and non-healthcare professionals.  
1160 This is independently of the condition of use of the suspected medicinal product and of the  
1161 expectedness of the adverse reaction.

##### 1162 **a. Serious ICSRs**

- 1163 • Marketing authorisation holders shall submit all serious ICSRs that occur within or outside the EU,  
1164 including those received from competent authorities outside the EU, to the EudraVigilance database  
1165 only.



- 1166 • Competent authorities in Member States shall submit to the EudraVigilance database all serious  
1167 ICSRs that occur in their territory and that are directly reported to them.

1168 **b. Non-Serious ICSRs**

- 1169 • Marketing authorisation holders shall submit all non-serious ICSRs that occur in the EU to the  
1170 EudraVigilance database only.

- 1171 • Competent authorities in Member States shall submit all non-serious ICSRs that occur in their  
1172 territory to the EudraVigilance database.

1173 Overviews of the reporting requirements of serious and non-serious reports, applicable to marketing  
1174 authorisation holders or competent authorities in Member States once the final arrangements are  
1175 implemented, are presented in [VI. Appendix 3.2](#), together with a detailed business process map.

1176 In accordance with the requirement detailed in Article 24(4) of Regulation (EC) No 726/2004 for the  
1177 final arrangements, the ICSRs submitted to the EudraVigilance database by marketing authorisation  
1178 holders shall be automatically transmitted upon receipt, to the competent authority of the Member  
1179 State where the reaction occurred. A detailed business process map is included in [VI. Appendix 3.3](#).

1180 **VI.C.5. Collaboration with the World Health Organization and the European**  
1181 **Monitoring Centre for Drugs and Drug Addiction**

1182 The Agency shall make available to the WHO Collaborating Centre for International Drug Monitoring all  
1183 suspected adverse reaction reports occurring in the EU [REG Art 28c(1)]. This will take place on a  
1184 weekly basis after their transmission to the EudraVigilance database by competent authorities in  
1185 Member States or marketing authorisation holders. It will replace the requirements of Member States  
1186 participating in the WHO Programme for International Drug Monitoring to directly report to WHO  
1187 suspected adverse reactions reports occurring in their territory. This will be implemented once the  
1188 functionalities of the EudraVigilance database specified in Article 24(2) of Regulation (EC) No 726/2004  
1189 are established.

1190 A detailed business process map for the reporting of ICSRs, from the EudraVigilance database to the  
1191 WHO Collaborating Centre for International Drug Monitoring, is presented in [VI. Appendix 4](#).

1192 The Agency and the European Monitoring Centre for Drugs and Drug Addiction shall also exchange  
1193 information that they receive on the abuse of medicinal products including information related to illicit  
1194 drugs [REG Art 28c(2)].

1195 **VI.C.6. Electronic exchange of safety information in the EU**

1196 Part VI.C.6 highlights the requirements, as defined in Articles 24(1) and 24(3) of Regulation (EC) No  
1197 726/2004, for the establishment and maintenance of the European database and data processing  
1198 network (the EudraVigilance database) in order to collate and share pharmacovigilance information  
1199 electronically between competent authorities in Member States, marketing authorisation holders and  
1200 the Agency, in ways which ensure the quality and integrity of the data collected.

1201 The information provided here is relevant for the electronic exchange of ICSRs in the EU between all  
1202 stakeholders and for the electronic submission of information on medicinal products to the Agency.

1203 **VI.C.6.1. Applicable guidelines, definitions, international formats,**  
1204 **standards and terminologies**

1205 For the classification, retrieval, presentation, risk-benefit evaluation and assessment, electronic  
1206 exchange and communication of pharmacovigilance and medicinal product information, Member  
1207 States, marketing authorisation holders and the Agency shall adhere to the legal requirements  
1208 provided in Chapter IV of the Commission Implementing Regulation (EU) No 520/2012.

1209 In addition the following guidelines should be applied:

- 1210 • Note for guidance - EudraVigilance Human - Processing of Safety Messages and Individual Case  
1211 Safety Reports (ICSRs) ([EMA/H/20665/04/Final Rev. 2](#)) (EudraVigilance Business Rules);
- 1212 • Note for Guidance on the Electronic Data Interchange (EDI) of Individual Case Safety Reports  
1213 (ICSRs) and Medicinal Products (MPRS) in Pharmacovigilance during the pre- and post-  
1214 authorisation phase in the European economic area (EEA) ([EMEA/115735/2004](#));
- 1215 • The ICH guidelines detailed in [VI.B.8](#);
- 1216 • The ICH-M5 guideline 'Routes of Administration Controlled Vocabulary' ([CHMP/ICH/175860/2005](#)),  
1217 which provides standard terms for routes of administration;

1218 The latest version of these documents should always be considered.

1219 **VI.C.6.2. Electronic Reporting of Individual Case Safety Reports**

1220 The reporting of valid ICSRs electronically, by competent authorities in Member States and marketing  
1221 authorisation holders, is mandatory for all medicinal products authorised in the EU [DIR Art 107(3), Art  
1222 107a(4)]. Non-adherence to this requirement constitutes a non-compliance with EU legislation.  
1223 Responsibilities in case of communication failure (including adherence to compliance for reporting) are  
1224 detailed in Chapter IV of the Note for Guidance on the Electronic Data Interchange (EDI) of Individual  
1225 Case Safety Reports (ICSRs) and Medicinal Product Reports (MPRs) in Pharmacovigilance during the  
1226 Pre- and Post-authorisation Phase in the European Economic Area (EEA) ([EMEA/115735/2004](#)).

1227 Technical tools (EVWEB) have been made available by the Agency to interested electronic data  
1228 interchange partners, including small and medium-sized enterprises, to facilitate compliance with the  
1229 electronic reporting requirements as defined in EU legislation. Information is available on  
1230 EudraVigilance website<sup>32</sup>.

1231 **VI.C.6.2.1. EudraVigilance Database Modules**

1232 Two modules are available in the EudraVigilance database to address the collection of reports of  
1233 suspected adverse reactions related to medicinal products for human use, in accordance with EU  
1234 legislation:

- 1235 • EudraVigilance Post-Authorisation Module (EVPM), implemented based on the requirements defined  
1236 in Regulation (EC) No 726/2004 and Directive 2001/83/EC, and
- 1237 • EudraVigilance Clinical Trial Module (EVCTM), implemented based on the requirements defined in  
1238 Directive 2001/20/EC.

---

<sup>32</sup> <http://eudravigilance.ema.europa.eu>

1239 **VI.C.6.2.1.1. Adverse reaction data collected in the EudraVigilance Post-Authorisation**  
1240 **Module**

1241 The adverse reaction reports collected in the EudraVigilance Post-Authorisation Module (EVP) refer to  
1242 unsolicited reports and solicited reports which do not fall under the scope of the Clinical Trials Directive  
1243 2001/20/EC (see [VI.C.1.](#)). The ICSRs should be submitted with the value 'EVHUMAN' in the data  
1244 element 'Message receiver identifier' (ICH M2 M.1.6).

1245 Depending on their type, these ICSRs should be classified with one of the following options, in  
1246 accordance with the EudraVigilance business rules<sup>33</sup>:

- 1247 • Data element 'Type of report' (ICH-E2B(R2) A.1.4):
  - 1248 – spontaneous report;
  - 1249 – other;
  - 1250 – not available to sender (unknown); or
  - 1251 – report from study.
- 1252 • In addition, when the value in the data element ICH-E2B(R2) A.1.4 is 'Report from study', the data  
1253 element 'Study type in which the reaction(s)/event(s) were observed' (ICH-E2B(R2) A.2.3.3)  
1254 should be populated with:
  - 1255 – individual patient use, e.g. compassionate use or named-patient basis, or
  - 1256 – other studies, e.g. pharmacoepidemiology, pharmacoconomics, intensive monitoring, PMS,  
1257 etc.

1258 **VI.C.6.2.1.2. Adverse Reaction Data Collected in the EudraVigilance Clinical Trial Module**

1259 Only cases of Suspected Unexpected Serious Adverse Reactions (SUSARs), related to investigational  
1260 medicinal products studied in clinical trials which fall under the scope of Directive 2001/20/EC (see  
1261 [VI.C.1.](#)), should be reported by the sponsor to the EudraVigilance Clinical Trial Module (EVCTM). The  
1262 requirements provided in Chapter II of [EudraLex Volume 10 of The Rules Governing Medicinal Products](#)  
1263 [in the European Union](#) should be applied. The ICSRs should be submitted with the value 'EVCTMPROD'  
1264 in the data element 'Message receiver identifier' (ICH M2 M.1.6) and should be classified as followed,  
1265 in accordance with the EudraVigilance business rules<sup>34</sup>:

- 1266 • data element 'Type of report' (ICH-E2B(R2) A.1.4):
  - 1267 – report from study; and
- 1268 • data element 'Study type in which the reaction(s)/event(s) were observed' (ICH-E2B(R2) A.2.3.3):
  - 1269 – clinical trials.

1270 **VI.C.6.2.2. Preparation of Individual Case Safety Reports**

1271 **VI.C.6.2.2.1. General principles**

1272 The content of each valid ICSR transmitted electronically between all stakeholders should comply with  
1273 the legal requirements and guidelines detailed in the Commission Implementing Regulation (EU) No  
1274 520/2012 and in [VI.C.6.1.](#), particularly:

---

<sup>33</sup> Note for guidance - EudraVigilance Human - Processing of Safety Messages and Individual Case Safety Reports (ICSRs) ([EMA/H/20665/04/Final Rev. 2](#)).

<sup>34</sup> See Footnote 33.

- 1275 • the requirements provided in Chapter IV and V of the Commission Implementing Regulation (EU)  
1276 No 520/2012;
- 1277 • the latest version of the ICH-endorsed guide for MedDRA users - MedDRA Term Selection: Points to  
1278 Consider Document ;
- 1279 • the EudraVigilance business rules for the electronic transmission of ICSRs detailed in the Note for  
1280 guidance - EudraVigilance Human - Processing of Safety Messages and Individual Case Safety  
1281 Reports (ICSRs) ([EMA/H/20665/04/Final Rev. 2](#)).

1282 It is recognised that it is often difficult to obtain all the details on a specific case. However, the  
1283 complete information (medical and administrative data) for a valid ICSR that is available to the sender  
1284 should be reported in a structured manner in the relevant ICH-E2B(R2) data elements (which should  
1285 be repeated as necessary when multiple information is available) and in the narrative section (see  
1286 [VI.C.6.2.2.4](#)). This applies to all types of ICSRs, such as reports with initial information on the case,  
1287 follow-up information and cases highlighted for nullification<sup>35</sup>.

1288 In the situation where it is evident that the sender has not transmitted the complete information  
1289 available on the case, the receiver may request the sender to re-transmit the ICSR within 24 hours  
1290 with the complete case information in electronic format in accordance with the requirements applicable  
1291 for the electronic reporting of ICSRs. This should be seen in the light of the qualitative signal detection  
1292 and evaluation activity, where it is important for the receiver to have all the available information on a  
1293 case to perform the medical assessment (see [VI.C.6.2.4](#)).

1294 Where the suspected adverse reactions reported in a single ICSR impact on the known risk-benefit  
1295 balance of a medicinal product, this should be considered as an Emerging Safety Issue (see  
1296 [VI.C.2.2.6](#)), which should be immediately notified in writing to the competent authorities of the  
1297 Member States where the medicinal product is authorised and to the Agency. This is in addition to the  
1298 reporting requirements detailed in [VI.C.4](#). A summary of the points of concerns and the action  
1299 proposed should be recorded in the ICSR in data element 'Sender's comments' (ICH-E2B(R2) B.5.4).

#### 1300 ***VI.C.6.2.2.2. Information on suspect, interacting and concomitant medicinal products***

1301 The suspect, interacting and/or concomitant active substances/invented names of the reported  
1302 medicinal products should be provided in accordance with [IR Art 28 (3) (g) to (i)], the ICH-E2B(R2)  
1303 guideline and the [EudraVigilance business rules](#).

1304 The characterisation of medicinal products as suspect, interacting or concomitant is based on the  
1305 information provided by primary source.

1306 For combination medicinal products, which contain more than one active substance, each active  
1307 substance needs to be reflected individually in the data element 'Active substance name(s)' (ICH  
1308 E2B(R2) B.4.k.2.2), which needs to be repeated for each active substance contained in the  
1309 combination medicinal product.

1310 When the primary source reports a suspect or interacting branded/proprietary medicinal product name  
1311 without indicating the active substance(s) of the medicinal product and where the proprietary  
1312 medicinal product can be one of two or more possible generics, which have a different composition  
1313 depending on the country where the medicinal product is marketed, the ICSR should be populated as  
1314 follows:

- 1315 • data element 'Proprietary medicinal product name' (ICH-E2B(R2) B.4.k.2.1) should be populated  
1316 with the proprietary/branded medicinal product name as reported by the primary source;

---

<sup>35</sup> See also [VI.C.6.2.2.10](#) on nullification of individual cases.

1317 • data element 'Active substance name(s)' (ICH-E2B(R2) B.4.k.2.2) should be completed with the  
1318 active substance(s) that correspond(s) to the composition of the proprietary/branded medicinal  
1319 product of the country where the reaction/event occurred.

1320 However if the information is available on:

- 1321 • the 'Identification of the country where the drug was obtained' (data element ICH E2B(R2)  
1322 B.4.k.2.3),
- 1323 • the 'Authorization/application number' (data element ICH-E2B(R2) B.4.k.4.1),
- 1324 • the 'Country of authorization/application' (data element ICH-E2B(R2) B.4.k.4.2), and/or
- 1325 • the 'Batch/lot number' (data element ICH-E2B(R2) B.4.k.3),

1326 the composition with regard the active substance(s) of the proprietary medicinal product should be  
1327 provided accordingly.

1328 Where the primary source reports a suspect or interacting branded/proprietary medicinal product name  
1329 without indicating the pharmaceutical form/presentation of the product and where the  
1330 proprietary/branded medicinal product can be one of two or more possible pharmaceutical  
1331 forms/presentations, which have different compositions in a country, the ICSR should be populated as  
1332 follows:

- 1333 • data element 'Proprietary medicinal product name' (ICH-E2B(R2) B.4.k.2.1) should be populated  
1334 with the medicinal product name as reported by the primary source;
- 1335 • data element 'Active substance name(s)' (ICH-E2B(R2) B.4.k.2.2) should be completed with those  
1336 active substances which are in common to all pharmaceutical forms/presentations in the country of  
1337 authorisation.

1338 Where medicinal products cannot be described on the basis of the active substances or the invented  
1339 names, for example when only the therapeutic class is reported by the primary source, or in case of  
1340 other administered therapies that cannot be structured, this information should only be reflected in the  
1341 case narrative (data element ICH-E2B(R2) B.5.1). The data elements 'Proprietary medicinal product  
1342 name' (ICH-E2B(R2) B.4.k.2.1) and 'Active substance name(s)' (ICH-E2B(R2) B.4.k.2.2) should not be  
1343 populated. The same applies if a suspected food interaction is reported (e.g. to grapefruit juice).

1344 Where a case of adverse reactions is reported to be related only to a therapeutic class, it is considered  
1345 incomplete and does not qualify for reporting (see [VI.B.2.](#)). Efforts should be made to follow-up the  
1346 case in order to collect the missing information regarding the suspected medicinal product (see  
1347 [VI.B.3.](#)).

1348 As regards the reporting of drug interactions, which concerns drug/drug (including biological products),  
1349 drug/food, drug/device, and drug/alcohol interactions, the coding of the interaction should be  
1350 performed in Section 'Reactions/Events' (ICH-E2B(R2) B.2) in line with the latest version of the **ICH-  
1351 Endorsed Guide for MedDRA Users - MedDRA Term Selection: Points to Consider Document**. In  
1352 addition, for drug/drug interactions, information on the active substances/proprietary medicinal  
1353 product names should be provided in the Section 'Drug information' (ICH-E2B(R2) B.4), which should  
1354 be characterised as interacting in the data element 'Characterisation of drug role' (ICH-E2B(R2)  
1355 B.4.k.1).

1356 If the primary source suspects a possible causal role of one of the ingredients (e.g., excipient or  
1357 adjuvant) of the suspected medicinal product, this information should be provided in the Section 'Drug  
1358 information' (ICH-E2B(R2) B.4) as a separate entry in addition to the information given regarding the  
1359 suspected medicinal product. This should also be specified in the case narrative (data element ICH-

1360 E2B(R2) B.5.1). If available, tests results (positive or negative) in relation to the causal role of the  
1361 suspected ingredient should be included in the section 'Results of tests and procedures relevant to the  
1362 investigation of the patient' (ICH E2B(R2) B.3).

#### 1363 **VI.C.6.2.2.3. Suspected adverse reactions**

1364 All available information as described in [IR Art 28 (3) (j)] shall be provided for each individual case.  
1365 The coding of diagnoses and provisional diagnoses with signs and symptoms in the data element  
1366 'Reaction/event in MedDRA terminology (Lowest Level Term)' (ICH-E2B(R2) B.2.i.1) should be  
1367 performed in line with the latest version of the ICH-Endorsed Guide for MedDRA Users, MedDRA Term  
1368 Selection: Points to Consider.

1369 In practice, if a diagnosis is reported with characteristic signs and symptoms, the preferred option is to  
1370 select a term for the diagnosis only and to MedDRA code it in the ICH-E2B(R2) section B.2  
1371 'Reaction(s)/event(s)'. If no diagnosis is provided, all reported signs and symptoms should be listed  
1372 and MedDRA coded in the ICH-E2B(R2) section B.2 'Reaction(s)/event(s)'. If these signs and  
1373 symptoms are typically part of a diagnosis, the diagnosis can be MedDRA coded in addition by  
1374 competent authorities in Member States or marketing authorisation holders in the ICH-E2B(R2) data  
1375 element B.5.3 'Sender's diagnosis/syndrome and/or reclassification of reaction/event'.

1376 If in the narrative other events have been reported, which are not typically signs or symptoms of the  
1377 primary source's diagnosis or provisional diagnosis, and those events are suspected to be adverse  
1378 reactions, they should also be listed and MedDRA coded in the ICH-E2B(R2) section B.2  
1379 'Reaction(s)/event(s)'.

1380 In case a competent authority in a Member State or a marketing authorisation holder disagrees with  
1381 the diagnosis reported by the primary source, an alternative diagnosis can be provided in the ICH-  
1382 E2B(R2) data element B.5.3 'Sender's diagnosis/syndrome and/or reclassification of reaction/event' in  
1383 addition to the reported diagnosis provided in the ICH-E2B(R2) section B.2 'Reaction(s)/event(s)'. In  
1384 this situation, a reasoning should be included in the data element 'Sender's comments' (ICH-E2B(R2)  
1385 B.5.4) (see [VI.C.6.2.2.4](#)).

1386 In the event of death of the patient, the date, cause of death including autopsy-determined causes  
1387 shall be provided as available [IR 28 (3) (l)]. If the death is unrelated to the reported suspected  
1388 adverse reaction(s) and is linked for example to disease progression, the seriousness criterion of the  
1389 ICSR should not be considered as fatal; the recommendation provided in the EudraVigilance Business  
1390 Rules should be followed.

#### 1391 **VI.C.6.2.2.4. Case narrative, causality assessment and comments**

1392 In accordance with [IR Art 28 (3) (m)], a case narrative (data element ICH-E2B(R2) B.5.1) shall be  
1393 provided, where possible<sup>36</sup>, for all cases with the exception of non-serious cases. The information shall  
1394 be presented in a logical time sequence, in the chronology of the patient's experience including clinical  
1395 course, therapeutic measures, outcome and follow-up information obtained. Any relevant autopsy or  
1396 post-mortem findings shall also be summarised.

1397 The narrative should be presented in line with the recommendations described in Chapter 5.2 of the  
1398 ICH-E2D guideline. In this aspect, it should serve as a comprehensive, stand-alone "medical report"  
1399 containing all known relevant clinical and related information, including patient characteristics, therapy  
1400 details, medical history, clinical course of the event(s), diagnosis, adverse reactions and their

---

<sup>36</sup> 'Where possible' should be interpreted as having received sufficient information from the primary source to prepare a concise clinical summary of the individual case.

1401 outcomes, relevant laboratory evidence (including normal ranges) and any other information that  
1402 supports or refutes the suspected adverse reactions. An example of a standard narrative template is  
1403 available in the [Report of the CIOMS Working Group V](#)<sup>37</sup>.

1404 The information provided in the narrative should be consistent with the data appropriately reflected in  
1405 all the other relevant ICH-E2B(R2) data elements of the ICSR.

1406 During the interim arrangements (see [VI.C.4.1.](#)), the case narratives included in the ICSRs submitted  
1407 to the competent authorities in Member States by marketing authorisation holders, should not be  
1408 modified or deleted when the ICSRs are forwarded to the EudraVigilance database by the competent  
1409 authorities.

1410 Where available, comments from the primary source on the diagnosis, causality assessment or other  
1411 relevant issue, should be provided in the data element 'Reporter's comments' (ICH-E2B(R2) B.5.2).  
1412 Competent authorities in Member States and marketing authorisation holders may provide an  
1413 assessment of the case and describe a disagreement with, and/or alternatives to the diagnoses given  
1414 by the primary source (see [VI.C.6.2.2.3.](#)). This should be done in the data element 'Sender's  
1415 comments' (ICH-E2B(R2) B.5.4), where discrepancies or confusions in the information notified by the  
1416 primary source may also be highlighted. Where applicable, a summary of the points of concerns and  
1417 actions proposed should also be included in the data element 'Sender's comments' (ICH-E2B(R2)  
1418 B.5.4), if the ICSR leads to notification of an Emerging Safety Issue (see [VI.C.2.2.6.](#)). The degree of  
1419 suspected relatedness of each medicinal product to the adverse reaction(s) may be indicated in the  
1420 data element 'Relatedness of drug to reaction(s)/event(s)' (ICH-E2B(R2) B.4.k.18), which should be  
1421 repeated as necessary. This also allows presenting the degree of relatedness from different sources or  
1422 with different methods of assessment.

#### 1423 **VI.C.6.2.2.5. Test results**

1424 Results of tests and procedures relevant to the investigation of the patient shall be provided [IR Art 28  
1425 (3) (k)].

1426 As described in the ICH-E2B(R2) guideline, the section B.3 'Results of tests and procedures relevant to  
1427 the investigation of the patient' should capture the tests and procedures performed to diagnose or  
1428 confirm the reaction/event, including those tests done to investigate (exclude) a non-drug cause, (e.g.,  
1429 serologic tests for infectious hepatitis in suspected drug-induced hepatitis). Both positive and negative  
1430 results should be reported.

1431 The coding of investigations should be performed in line with the latest version of the [ICH-Endorsed  
1432 Guide for MedDRA Users, MedDRA Term Selection: Points to Consider](#). If it is not possible to provide  
1433 information on tests and test results in a structured manner, provisions have been made to allow for  
1434 the transmission of the information as free text in the data element ICH-E2B(R2) B.3.2. 'Results of  
1435 tests and procedures relevant to the investigation'.

#### 1436 **VI.C.6.2.2.6. Supplementary information**

1437 Key information from supplementary records should be provided in the relevant section of the ICSR,  
1438 and their availability should be mentioned in the data element 'List of documents held by sender' (ICH-  
1439 E2B(R2) A.1.8.2).

---

<sup>37</sup> Council for International Organizations of Medical Sciences (CIOMS). Current Challenges in Pharmacovigilance: Pragmatic Approaches (CIOMS V). Geneva: CIOMS; 2001. <http://www.cioms.ch/>.

1440 Other known case identifiers relevant for the detection of duplicates should be presented  
1441 systematically in the data element 'Other case identifiers in previous transmissions' (ICH-E2B(R2)  
1442 A.1.11).

#### 1443 **VI.C.6.2.2.7. Follow-up information**

1444 ICSRs are sent at different times to multiple receivers. Therefore the initial/follow-up status is  
1445 dependent upon the receiver. For this reason an item to capture follow-up status is not included in the  
1446 ICH-E2B(R2) data elements. However, the data element 'Date of receipt of the most recent information  
1447 for this report' (ICH-E2B(R2) A.1.7) taken together with the data element 'Sender identifier' (ICH  
1448 E2B(R2) A.3.1.2) and the data element 'Sender's (case) report unique identifier' (ICH-E2B(R2)  
1449 A.1.0.1) provide a mechanism for each receiver to identify whether the report being transmitted is an  
1450 initial or a follow-up report. For this reason these items are considered critical for each transmission  
1451 and a precise date should always be used (i.e. day, month, year). The data element 'Date of receipt of  
1452 the most recent information for this report' (ICH-E2B(R2) A.1.7) should therefore always be updated  
1453 each time a follow-up information is received by a competent authority or a marketing authorisation  
1454 holder, independently whether the follow-up information received is significant enough to be reported.  
1455 The data element 'Date report was first received from the source' (ICH-E2B(R2) A.1.6) should remain  
1456 unchanged to the date the competent authority or the marketing authorisation holder became aware of  
1457 the initial report.

1458 New information should be clearly identifiable in the case narrative (data element ICH-E2B(R2) B.5.1)  
1459 and provided in a structured format in the applicable ICH-E2B(R2) data elements.

1460 Competent authorities in Member States or marketing authorisation holders should report follow-up  
1461 information if significant new medical information has been received. Significant new information  
1462 relates to for example new suspected adverse reaction(s), a change in the causality assessment and  
1463 any new or updated information on the case that impacts on its medical interpretation. Therefore, the  
1464 identification of significant new information requiring to be reported always necessitates medical  
1465 judgement.

1466 Situations where the seriousness criteria and/or the causality assessment are downgraded (e.g. follow-  
1467 up information leads to a change of the seriousness criteria from serious to non-serious; causality  
1468 assessment is changed from related to non-related) should also be considered as significant changes  
1469 and thus reported (see [VI.B.7.1.](#) for reporting time frames).

1470 In addition, competent authorities in Member States or marketing authorisation holders should also  
1471 report follow-up information, where new administrative information is available, that could impact on  
1472 the case management; for example, if new case identifiers have become known to the sender, which  
1473 may have been used in previous transmissions (data element 'Other case identifiers in previous  
1474 transmissions' (ICH-E2B(R2) A.1.11)). This information may be specifically relevant to manage  
1475 potential duplicates. Another example refers to data element 'Additional available documents held by  
1476 sender' (ICH-E2B(R2) A.1.8), whereby new documents that have become available to the sender may  
1477 be relevant for the medical assessment of the case.

1478 In contrast, a follow-up report which contains non-significant information does not require to be  
1479 reported. This may refer, for example, to minor changes to some dates in the case with no implication  
1480 for the evaluation or transmission of the case, or corrections of typographical errors in the previous  
1481 case version. Medical judgement should be applied since a change to the birth date may constitute a  
1482 significant modification (e.g. with implications on the age information of the patient). Similarly, a  
1483 change of the status of a MedDRA code/term from current to non-current, due to a version change of  
1484 MedDRA, can be considered as a non-significant change as long as this change has no impact on the



1485 medical content of a case. However, an amendment of the MedDRA coding due to a change in the  
1486 interpretation of a previously reported suspected adverse reaction may constitute a significant change  
1487 and therefore should be reported.

1488 In situations where the case is modified without impacting on its medical evaluation, while no new  
1489 follow-up is received (e.g., for correcting a mistake or typographical error), the date of receipt of the  
1490 most recent information reported in the data element 'Date of receipt of the most recent information  
1491 for this report' (ICH-E2B(R2) A.1.7 ) should not be changed. This data element should however be  
1492 updated in any other situations, to the date when new follow-up information is received (independently  
1493 whether it is significant or not) or to the date when changes are made which impact on the  
1494 interpretation of the case.

1495 Where follow-up information of a case initially reported by a marketing authorisation holder is received  
1496 directly by a competent authority, the 'Worldwide unique case identification number' (ICH-E2B(R2)  
1497 A.1.10) of the initial report should be maintained, in adherence with the ICH-E2B(R2) rules. The same  
1498 principle should be applied if a follow-up is received by a marketing authorisation holder of a case  
1499 initially reported by a competent authority.

#### 1500 **VI.C.6.2.2.8. What to take into account for data privacy laws**

1501 To detect, assess, understand and prevent adverse reactions and to identify, and take actions to  
1502 reduce the risks of, and increase the benefits from medicinal products for the purpose of safeguarding  
1503 public health, the processing of personal data within the EudraVigilance database is possible while  
1504 respecting EU legislation in relation to data protection (Directive 95/46/EC, Regulation (EC) No  
1505 45/2001).

1506 Where in accordance with applicable national legislation, information related to personal data cannot  
1507 be transferred to the EudraVigilance database, pseudonymisation may be applied by competent  
1508 authorities in Member States and by marketing authorisation holders, thereby replacing identifiable  
1509 personal data such as name and address with pseudonyms or key codes, for example in accordance  
1510 with the ISO Technical Specification DD ISO/TS 25237:2008, Health informatics – Pseudonymization  
1511 [IR Recital 17]. The application of pseudonymisation will facilitate the ability of the EudraVigilance  
1512 system to adequately support case processing and detect duplicates. This should however be done  
1513 without impairing the information flow in the EudraVigilance database and the interpretation and  
1514 evaluation of safety data relevant for the protection of public health; given the high-level nature of the  
1515 information, data elements such as patient's age, age group and gender should in principle be kept un-  
1516 redacted/visible.

#### 1517 **VI.C.6.2.2.9. Handling of languages**

1518 The ICH-E2B(R2) concept for the electronic reporting of ICSRs is based on the fact that structured and  
1519 coded information is used for data outputs of pharmacovigilance systems (e.g. listings) and for signal  
1520 detection. However, for scientific case assessment and signal evaluation, the medical summary  
1521 provided in the data element 'Case narrative including clinical course, therapeutic measures, outcome  
1522 and additional relevant information' (ICH-E2B(R2) B.5.1) is normally required (see [VI.6.2.2.4](#)).

1523 Where suspected adverse reactions are reported **by the primary source** in narrative and textual  
1524 descriptions in an official language of the Union other than English, the original verbatim text and the  
1525 summary thereof in English shall be provided by the marketing authorisation holder<sup>38</sup>. Member States

---

<sup>38</sup> In practice, the original verbatim text reported by the primary source in an official language of the Union other than English should be included in the ICSR, if it is requested by the Member State where the reaction occurred or by the Agency.

1526 may report case narratives in their official language(s). For those reports, case translations shall be  
1527 provided when requested by the Agency or other Member States for the evaluation of potential signals.  
1528 For suspected adverse reactions originating outside the EU, English shall be used in the ICSR [IR 28  
1529 (4)].

1530 Additional documents held by the sender, which may be only available in a local language, should only  
1531 be translated if requested by the receiver.

#### 1532 **VI.C.6.2.2.10. Nullification of cases**

1533 In line with the ICH-E2B(R2) guideline, the nullification of individual cases should be used to indicate  
1534 that a previously transmitted report should be considered completely void (nullified), for example when  
1535 the whole case was found to be erroneous or in case of duplicate reports. It is essential to use the  
1536 same case report numbers previously submitted in the data element 'Sender's (case) safety report  
1537 unique identifier' (ICH-E2B(R2) A.1.0.1) and in the data element 'Worldwide unique case identification  
1538 number' (ICH-E2B(R2) A.1.10).

1539 A nullified case is one that should no longer be considered for scientific evaluation. The process of the  
1540 nullification of a case is by means of a notification by the sender to the receiver that this is no longer a  
1541 valid case. However, the case should be retained in the sender's pharmacovigilance database for  
1542 auditing purposes.

1543 The principles to be considered when nullifying a case are detailed in [VI. Appendix 5](#).

#### 1544 **VI.C.6.2.3. Special situations**

##### 1545 **VI.C.6.2.3.1. Use of a medicinal product during pregnancy or breastfeeding**

1546 General recommendations are provided in [VI.B.6.1.](#)

1547 With regard to the electronic reporting of parent-child/foetus cases, the following should be adhered  
1548 to:

- 1549 • In the situation where a foetus or nursing infant is exposed to one or several medicinal products  
1550 through the parent and experiences one or more suspected adverse reactions (other than early  
1551 spontaneous abortion/foetal demise), information on both the parent and the child/foetus should  
1552 be provided in the same report. These cases are referred to as parent-child/foetus reports. The  
1553 information provided in the section 'Patients characteristics' (ICH-E2B(R2) B.1) applies only to the  
1554 child/foetus. The characteristics concerning the parent (mother or father), who was the source of  
1555 exposure to the suspect medicinal product should be provided in the data element 'For a parent-  
1556 child/fetus report, information concerning the parent' (ICH-E2B(R2) B.1.10). If both parents are  
1557 the source of the suspect drug(s) then the case should reflect the mother's information in the data  
1558 element 'For a parent-child/fetus report, information concerning the parent' (ICH E2B(R2) B.1.10).  
1559 The data element 'Case narrative including clinical course, therapeutic measures, outcome and  
1560 additional relevant information' (ICH-E2B(R2) B.5.1) should describe the entire case, including the  
1561 father's information.
- 1562 • If both the parent and the child/foetus experience suspected adverse reactions, two separate  
1563 reports, i.e. one for the parent (mother or father) and one for the child/foetus, should be created  
1564 but they should be linked by using the data element 'Identification number of the report which is  
1565 linked to this report' (ICH-E2B(R2) A.1.12) in each report.

- 1566 • If there has been no reaction affecting the child, the parent-child/foetus report does not apply; i.e.  
1567 the section 'Patients characteristics' (ICH-E2B(R2) B.1) applies only to the parent (mother or  
1568 father) who experienced the suspected adverse reaction.
- 1569 • For those cases describing miscarriage or early spontaneous abortion, only a parent report is  
1570 applicable, i.e. the section 'Patients characteristics' (ICH-E2B(R2) B.1) apply to the mother.  
1571 However, if the suspect medicinal product was taken by the father, the data element 'Additional  
1572 information on drug' (ICH-E2B(R2) B.4.k.19) should specify that the medication was taken by the  
1573 father.

1574 **VI.C.6.2.3.2. Suspected adverse reaction reports published in the scientific and medical**  
1575 **literature**

1576 EU requirements in relation to the monitoring of suspected drug reactions reported in the scientific and  
1577 medical literature are provided in [VI.C.2.2.3.](#) With regard to the electronic reporting of ICSRs  
1578 published in the scientific and medical literature, the following applies:

- 1579 • The literature references shall be included in the data element 'Literature reference(s)' (ICH-  
1580 E2B(R2) A.2.2) in the Vancouver Convention (known as "Vancouver style"), developed by the  
1581 International Committee of Medical Journal Editors [IR Art 28 (3) (b)]. The standard format as well  
1582 as those for special situations can be found in the following reference: International Committee of  
1583 Medical Journal Editors. Uniform requirements for manuscripts submitted to biomedical journals. *N*  
1584 *Engl J Med.* 1997; 336: 309-15, which is in the Vancouver style<sup>39</sup>.
- 1585 • A comprehensive English summary of the article shall be provided in the data element 'Case  
1586 narrative including clinical course, therapeutic measures, outcome and additional relevant  
1587 information' (ICH-E2B(R2) B.5.1) [IR Art 28 (3) (b)].
- 1588 • Upon request of the Agency, for specific safety review, a full translation in English and a copy of  
1589 the relevant literature article shall be provided by the marketing authorisation holder that  
1590 transmitted the initial report, taking into account copyright restrictions [IR 28 (3)]. The  
1591 recommendations detailed in [VI.App2.10](#), regarding the mailing of the literature article, should be  
1592 adhered to.
- 1593 • Recommendations presented in [VI.App2.10](#), for the reporting of several cases when they are  
1594 published in the same literature article, should be followed.

1595 **VI.C.6.2.3.3. Suspected adverse reactions related to overdose, abuse, off-label use, misuse,**  
1596 **medication error or occupational exposure**

1597 General principles are provided in [VI.B.6.3.](#)

1598 If a case of overdose, abuse, off-label use, misuse, medication error or occupational exposure is  
1599 reported with clinical consequences, the MedDRA Lowest Level Term code, corresponding to the term  
1600 closest to the description of the reported overdose, abuse, off-label use, misuse, medication error or  
1601 occupational exposure should be added to the observed suspected adverse reaction(s) in the data  
1602 element 'Reaction/event in MedDRA terminology (Lowest Level Term)' (ICH-E2B(R2) B.2.i.1), in line  
1603 with recommendations included in the latest version of the [ICH-Endorsed Guide for MedDRA Users](#)  
1604 'MedDRA Term Selection: Points to Consider'.

---

<sup>39</sup> The Vancouver recommendations are also available on the International Committee of Medical Journal Editors website  
<http://www.icmje.org>.

1605 **VI.C.6.2.3.4. Lack of therapeutic efficacy**

1606 General principles are provided in [VI.B.6.4.](#)

1607 If the primary source suspects a lack of therapeutic efficacy, the MedDRA Lowest Level Term code,  
1608 corresponding to the term closest to the description of the reported lack of therapeutic efficacy, should  
1609 be provided in the data element 'Reaction/event in MedDRA terminology (Lowest Level Term)' (ICH-  
1610 E2B(R2) B.2.i.1), in line with recommendations included in the latest version of the [ICH-Endorsed](#)  
1611 [Guide for MedDRA Users 'MedDRA Term Selection: Points to Consider'](#).

1612 Unless aggravation of the medical condition occurs, the indication for which the suspected medicinal  
1613 product was administered should not be included in the data element 'Reaction/event in MedDRA  
1614 terminology (Lowest Level Term).

1615 The same reporting modalities as for serious ICSRs (see [VI.C.4.](#)) should be applied for those cases  
1616 related to classes of medicinal products where, as described in [VI.B.6.4.](#), reports of lack of therapeutic  
1617 efficacy should be reported within a 15-day time frame. If no seriousness criterion is available, it is  
1618 acceptable to submit the ICSR within 15 days as non-serious.

1619 **VI.C.6.2.3.5. Suspected adverse reactions related to quality defect or falsified medicinal**  
1620 **products**

1621 EU requirements are provided in [VI.C.2.2.4.](#) In order to be able to clearly identify cases related to  
1622 quality defect or falsified medicinal products when they are exchanged between stakeholders, the  
1623 following recommendations should be applied:

1624 **a. Quality defect**

1625 Where a report of suspected adverse reactions is associated with a suspected or confirmed quality  
1626 defect of a medicinal product, the MedDRA Lowest Level Term code of the term corresponding most  
1627 closely to the product quality issue, should be added to the observed suspected adverse reaction(s) in  
1628 the data element 'Reaction/event in MedDRA terminology (Lowest Level Term)' (ICH-E2B(R2) B.2.i.1).

1629 **b. Falsified medicinal products**

1630 Where a report of suspected adverse reactions is associated with a suspected or confirmed falsified<sup>40</sup>  
1631 ingredient, active substance or medicinal product, the MedDRA Lowest Level Term code of the term  
1632 corresponding most closely to the reported information should be added to the observed suspected  
1633 adverse reaction(s) in the data element 'Reaction/event in MedDRA terminology (Lowest Level Term)'  
1634 (ICH-E2B(R2) B.2.i.1). Information on the suspected medicinal product, active substance(s) or  
1635 excipient(s) should be provided in the data elements 'Proprietary medicinal product name' (ICH-  
1636 E2B(R2) B.4.k.2.1) and/or 'Active substance name(s)' (ICH-E2B(R2) B.4.k.2.2) as reported by the  
1637 primary source.

1638 **VI.C.6.2.3.6. Suspected transmission via a medicinal product of an infectious agent**

1639 EU requirements are provided in [VI.C.2.2.5.](#)

1640 The coding of a suspected transmission of an infectious agent via a medicinal product in the data  
1641 element 'Reaction/event in MedDRA terminology (Lowest Level Term)' (ICH-E2B(R2) B.2.i.1 ) should  
1642 be performed in line with the latest version of the [ICH-Endorsed Guide for MedDRA Users 'MedDRA](#)  
1643 [Term Selection: Points to Consider'](#).

---

<sup>40</sup> As presented in EU legislation ([Directive 2011/62/EU](#)).

1644 In addition, if the infectious agent is specified, the MedDRA Lowest Level Term code corresponding to  
1645 the infectious agent should also be included in the data element 'Reaction/event in MedDRA  
1646 terminology (Lowest Level Term)' (ICH-E2B(R2) B.2.i.1).

#### 1647 **VI.C.6.2.3.7. Reports originating from organised data collection systems and other systems**

1648 General safety reporting requirements in the EU for post-authorisation studies are provided in [VI.C.1.](#)  
1649 and [VI.C.2.2.2.](#) Individual case safety reports originating from those studies shall contain information  
1650 on study type, study name and the sponsor's study number or study registration number [IR Art 28  
1651 (3)(c)]. This should be provided in ICH E2B(R2) section A.2.3 'Study identification'.

1652 Safety reporting requirements regarding patient support programmes or market research programmes  
1653 are provided in [VI.C.2.2.11.](#)

1654 The following reporting rules should be applied based on (i) the type of data collection system and (ii)  
1655 whether the suspected medicinal product is part of the scope of the data collection system.

1656 1. For all patient support programmes, **market research programme**, non-interventional studies with  
1657 primary data collection from consumers and healthcare professionals, and for certain compassionate  
1658 use or named patient use where adverse events are actively sought:

1659 a) Where the adverse reaction is suspected to be related at least to the studied (or supplied)  
1660 medicinal product:

- 1661 • the report should be considered as solicited;
- 1662 • the ICH E2B(R2) data element A.1.4 'Type of report' should be populated with the value 'Report  
1663 from study';
- 1664 • the ICH E2B(R2) data element A.2.3.3 'Study type in which the reaction(s)/event(s) were  
1665 observed' should be populated with the value 'Other studies' or 'Individual patient use'.

1666 b) Where the adverse reaction is only suspected to be related to a medicinal product which is not  
1667 subject to the scope of the organised data collection system and there is no interaction with the  
1668 studied (or supplied) medicinal product:

- 1669 • the report should be considered as spontaneous report; as such it conveys the suspicion of the  
1670 primary source;
- 1671 • The ICH E2B(R2) data element A.1.4 'Type of report' should be populated with the value  
1672 'Spontaneous'.

1673 2. For certain compassionate use or named patient use where adverse event reporting is not solicited:

- 1674 • the report should be considered as spontaneous report; as such it conveys the suspicion of the  
1675 primary source;
- 1676 • The ICH E2B(R2) data element A.1.4 'Type of report' should be populated with the value  
1677 'Spontaneous'.

1678 3. For clinical trial conducted in accordance with Directive 2001/20/EC and where the adverse reaction  
1679 is only suspected to be related to a non-investigational medicinal product (or another medicinal  
1680 product which is not subject to the scope of the clinical trial) and there is no interaction with the  
1681 investigational medicinal product:

- 1682 • the report should be considered as spontaneous report; as such it conveys the suspicion of the  
1683 primary source;

- 1684 • The ICH E2B(R2) data element A.1.4 'Type of report' should be populated with the value  
1685 'Spontaneous'.

1686 All ICSRs which are reportable to the EudraVigilance database and which originate from post-  
1687 authorisation studies which do not fall under the scope of the clinical trials Directive 2001/20/EC,  
1688 should be submitted to EVPM (see [VI.C.6.2.1.](#)). The same applies to cases of adverse reactions  
1689 originating in clinical trials if they are not suspected to be related to the investigational medicinal  
1690 product.

#### 1691 **VI.C.6.2.3.8. Receipt of missing minimum information**

1692 When missing minimum information (see [VI.B.2.](#)) has been obtained about a non-valid ICSR, the  
1693 following rules should be applied:

- 1694 • the data element 'Date report was first received from source' (ICH-E2B(R2) A.1.6) should contain  
1695 the date of receipt of the initial non-valid ICSR;
- 1696 • the data element 'Date of receipt of the most recent information for this report' (ICH-E2B(R2)  
1697 A.1.7) should contain the date when all the four elements of the minimum information required for  
1698 reporting have become available;
- 1699 • clarification should be provided in the case narrative (data element ICH-E2B(R2) B.5.1) that some  
1700 of the four elements were missing in the initial report.;
- 1701 • as for any reported cases, compliance monitoring is performed against the data element 'Date of  
1702 receipt of the most recent information for this report' (ICH-E2B(R2) A.1.7).

#### 1703 **VI.C.6.2.4. Data quality of individual case safety reports transmitted electronically and** 1704 **duplicate management**

1705 The EudraVigilance database should contain all cases of suspected adverse reactions that are  
1706 reportable according to Directive 2001/83/EC and Regulation (EC) No 726/2004 to support  
1707 pharmacovigilance activities. This applies to all medicinal products authorised in the EU independent of  
1708 their authorisation procedure.

1709 The EudraVigilance database should also be based on the highest internationally recognised data  
1710 quality standards.

1711 To achieve these objectives, all competent authorities in Member States and marketing authorisation  
1712 holders should adhere to:

- 1713 • the electronic reporting requirements as defined in EU legislation;
- 1714 • the concepts of data structuring, coding and reporting in line with the EU legislation, guidelines,  
1715 standards and principles referred to in [VI.C.6.2.2.1.](#)

1716 This is a pre-requisite to maintain a properly functioning EudraVigilance database intended to fully  
1717 support the protection of public health.

1718 The Agency shall, in collaboration with the stakeholder that submitted an ICSR to the EudraVigilance  
1719 database, be responsible for operating procedures that ensure the highest quality and full integrity of  
1720 the information collected in the EudraVigilance database [REG Art 24(3)]. This includes as well the  
1721 monitoring of use of the terminologies referred to in Chapter IV of the Commission Implementing  
1722 Regulation (EU) No 520/2012 [IR Art 25(3)].

1723 Specific quality system procedures and processes shall be in place in order to ensure

- 1724 • the submission of accurate and verifiable data on serious and non-serious suspected adverse  
1725 reactions to the EudraVigilance database within the 15 or 90-day time frame [IR Art 11 (1) (c)],
- 1726 • the quality, integrity and completeness of the information submitted on the risks of medicinal  
1727 products, including processes to avoid duplicate submissions [IR Art 11 (1) (d)].

1728 In this regard, marketing authorisation holders and competent authorities in Member States should  
1729 have in place an audit system, which ensures the highest quality of the ICSRs transmitted  
1730 electronically to the EudraVigilance database within the correct time frames, and which enables the  
1731 detection and management of duplicate ICSRs in their system. Those transmitted ICSRs should be  
1732 complete, entire and undiminished in their structure, format and content.

1733 High level business process maps and process descriptions in relation to the quality review of ICSRs  
1734 and the detection and management of duplicate ICSRs are provided in [VI. Appendix 6](#) and [VI.  
1735 Appendix 7](#). Further guidance on the detection of duplicate ICSRs is available in the [Guideline on the  
1736 Detection and Management of Duplicate Individual Cases and Individual Case Safety Reports \(ICSRs\),  
1737 EMA/13432/2009](#).

1738 A review of the ICSRs quality, integrity and compliance with the reporting time frames will be  
1739 performed by the Agency at regular intervals for all organisations reporting to the EudraVigilance  
1740 database. Feedback from these reviews will be provided to those organisations.

#### 1741 **VI.C.6.2.5. Electronic re-transmission of ICSRs between multiple senders and receivers**

1742 The electronic re-transmission of cases refers to the electronic exchange of ICSRs between multiple  
1743 senders and receivers, for example where in case of contractual agreement, a third country ICSR is  
1744 first reported by a marketing authorisation holder outside the EU to another marketing authorisation  
1745 holder in the EU and from there to the Agency. This applies as well for the interim arrangements  
1746 period, where based on the reporting requirements detailed in [VI.C.4.1](#), ICSRs originating in the EU  
1747 are submitted by marketing authorisation holders to the competent authorities in the Member State  
1748 where the reaction occurred and then re-transmitted to the EudraVigilance database.

1749 During this re-transmission process, information on the case should not in principle be omitted or  
1750 changed if no new information on the case is available to the re-transmitting sender.

1751 Exceptions apply to the following data elements or sections:

- 1752 • ‘Sender’s (case) safety report unique identifier’ (ICH-E2B(R2) A.1.0.1);
- 1753 • ‘Date of this transmission’ (ICH-E2B(R2) A.1.3);
- 1754 • ‘Date report was first received from source’ (ICH-E2B(R2) A.1.6), for initial reports;
- 1755 • ‘Date of receipt of the most recent information for this report’ (ICH-E2B(R2) A.1.7);
- 1756 • ‘Information on sender and receiver of case safety report’ (ICH-E2B(R2) A.3);
- 1757 • ‘Relatedness of drug to reaction(s)/event(s)’ (ICH-E2B(R2) B.4.k.18);
- 1758 • ‘Sender’s diagnosis/syndrome and/or reclassification of reaction/event’ (ICH-E2B(R2) B.5.3);
- 1759 • ‘Sender’s comments’ (ICH-E2B(R2) B.5.4).

1760 In the interest of improving data quality, in case of errors or inconsistencies in the report, the re-  
1761 transmitters should go back to the originator of the report to correct the case accordingly. However, if  
1762 this cannot be done within normal reporting time frame, the re-transmitter can correct information that  
1763 has been incorrectly structured.

1764 In addition, any electronic data interchange partner should adhere to the ICH-E2B(R2) rules regarding  
1765 the provision of follow-up information, whereby the 'Worldwide unique case identification number'  
1766 (ICH-E2B(R2) A.1.10) should be maintained in accordance with the ICH-E2B(R2) guideline. Non-  
1767 adherence to these administrative requirements endangers the electronic case management and leads  
1768 to the potential for unnecessary duplication of reports in the receiver's database.

#### 1769 **VI.C.6.2.6. Electronic reporting through company's headquarters**

1770 If a pharmaceutical company decides to centralise the electronic reporting of ICSRs (e.g. by reporting  
1771 through the company's global or EU headquarter), the following should be taken into account:

- 1772 • the central reporting arrangement should be clearly specified in the marketing authorisation  
1773 holder's pharmacovigilance system master file and in the internal standard operating procedures;
- 1774 • the company's headquarter designated for reporting the ICSRs should be registered with  
1775 EudraVigilance;
- 1776 • the same principles may be applied for reporting ICSRs from the competent authorities in Member  
1777 States to the marketing authorisation holders during the interim arrangements period, that is the  
1778 competent authorities in Member States report electronically to the company's headquarter instead  
1779 of to the local affiliates.

#### 1780 **VI.C.6.3. Electronic submission of information on medicinal products**

1781 To support the objectives of Directive 2001/83/EC and Regulation (EC) No 726/2004, the provisions  
1782 provided in second sub-paragraph of Article 57(2) of Regulation (EC) No 726/2004, regarding the  
1783 electronic submission and update of information on medicinal products for human use authorised or  
1784 registered in the EU, shall be followed by marketing authorisation holders. In this aspect marketing  
1785 authorisation holders shall apply the internationally agreed formats and terminologies described in  
1786 Chapter IV of the Commission Implementing Regulation (EU) No 520/2012. Recommendations related  
1787 to the electronic submission of information on medicines are provided on the Agency's website<sup>41</sup>.

1788

---

<sup>41</sup> EMA documents for electronic submission of information on medicines  
([http://www.ema.europa.eu/ema/index.jsp?curl=pages/regulation/document\\_listing/document\\_listing\\_000336.jsp&murl=menus/regulations/regulations.jsp&mid=WC0b01ac0580410138&jsenabled=true](http://www.ema.europa.eu/ema/index.jsp?curl=pages/regulation/document_listing/document_listing_000336.jsp&murl=menus/regulations/regulations.jsp&mid=WC0b01ac0580410138&jsenabled=true))



1789 **VI.APPENDICES**

1790

1791 **VI.Appendix 1 Identification of biological medicinal**  
 1792 **products**<sup>42</sup>

1793 **Figure VI.2.** Business process map - Identification of biological medicinal products

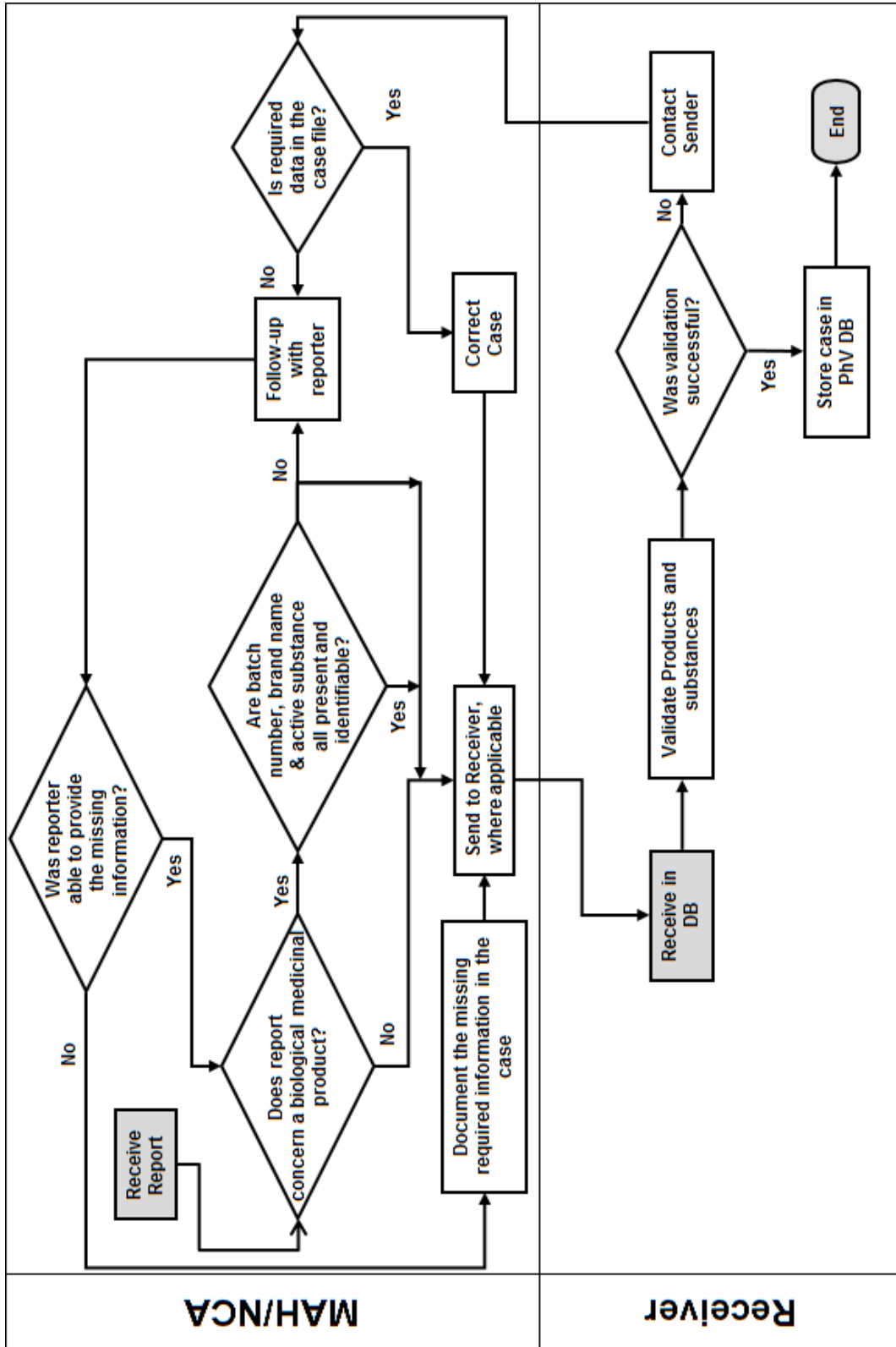

1794  
1795

<sup>42</sup> Mandatory when they are the subject of reports of suspected adverse reactions [DIR Art 102(e) and IR Art 28 (3)].

1796 **Table VI.1.** Process description - Identification of biological medicinal products

| No.        | Step  | Description  | Responsible Organisation |
|------------|---|--|--------------------------|
| <b>1</b>   | <b>Start.<br/>Receive report.</b>   | <b>Day 0. Receipt of the information for the case that indicates that one of the suspect drugs is of biological origin.</b>  | <b>MAH/NCA</b>           |
| 2          | Does report concern a biological medicinal product?                           | If Yes, go to step 3<br>If No, go to step 4  |                          |
| 3          | Are batch number, brand name & active substance all present and identifiable? | If Yes, create the case and send it to the correct receiver (step 3).<br>If there is more than one batch number, structure the batch number that coincided with the adverse reaction in the Drug section (ICH-E2B(R2) B.4) and enter the other batch numbers in the case narrative.<br>If No, create the case and send it to the correct receiver (step 3) and follow-up with the reporter (step 3.1). | MAH/NCA                  |
| 3.1        | Follow-up with reporter.  | Follow-up with the reporter to attempt to identify the missing information.  | MAH/NCA                  |
| 3.2        | Was reporter able to provide the missing information?                         | If Yes, return to step 1 – the information should be treated as follow-up and a new version created & transmitted.<br>If No, document this (step 3.3).   | MAH/NCA                  |
| 3.3        | Document the required missing information in the case.                        | Document in the case that the missing required information has been sought but the reporter was not able or willing to provide it.   | MAH/NCA                  |
| 4          | Send to receiver, where applicable.   | If the case requires transmission to a receiver, transmit the case electronically, in E2B(R2) format within the relevant timelines (15 or 90 days), to the relevant receiver.  | MAH/NCA                  |
| <b>5</b>   | <b>Receive in DataBase (DB).</b>  | Receive the case electronically and load it into the pharmacovigilance database.   | <b>Receiver</b>          |
| 6          | Validate products and substances  | Validate the products and substances to ensure that the brand name, active substance & batch number are all present and identifiable.<br>This validation should be complementary to the usual business rules validations.  | Receiver                 |
| 7          | Was validation successful?  | If Yes, store the case in the pharmacovigilance database (step 8).<br>If No, contact the sender (Step 7.1).  | Receiver                 |
| 7.1        | Contact sender.   | Contact the sender regarding the missing or not identifiable information.  | Receiver                 |
| <b>7.2</b> | <b>Is required data in the case</b>   | Upon receipt of communication from the   | <b>MAH/NCA</b>           |

| No.      | Step  | Description  | Responsible Organisation |
|----------|---|--|--------------------------|
|          | <b>file?</b>  | receiver, check in the case file to see if the missing or unidentifiable information is already on file.<br>If it is on file, correct the case (step 7.3).<br>If the information is not on file, contact the reporter to request the missing information (step 3.1). |                          |
| 7.3      | Correct case.   | Correct the case to include the missing information & send updated version to receiver (step 4).   | MAH/NCA                  |
| <b>8</b> | <b>Store case in Pharmacovigilance DataBase (PhV DB).</b> | The case should now be stored in the pharmacovigilance database.   | <b>Receiver</b>          |
| <b>9</b> | <b>End.</b>   | <b>The case is now available for signal detection and data quality analyses.</b>   |                          |

1797

1798 **VI.Appendix 2 Detailed guidance on the monitoring of**  
1799 **scientific and medical literature**

1800 ***VI.App2.1. When to start and stop searching in the scientific and medical***  
1801 ***literature***

1802 EU specific requirements, as regards the monitoring of scientific and medical literature are provided in  
1803 [VI.C.2.2.3.](#)

1804 In addition to the reporting of serious and non-serious ICSRs or their presentation in periodic safety  
1805 update reports, the marketing authorisation holder has an obligation to review the worldwide  
1806 experience with medicinal product in the period between the submission of the marketing authorisation  
1807 application and the granting of the marketing authorisation. The worldwide experience includes  
1808 published scientific and medical literature. For the period between submission and granting of a  
1809 marketing authorisation, literature searching should be conducted to identify published articles that  
1810 provide information that could impact on the risk-benefit assessment of the product under evaluation.  
1811 For the purpose of the preparation of periodic safety update reports (see Module VII) and the  
1812 notification of Emerging Safety Issues (see [VI.C.2.2.6.](#)), the requirement for literature searching is not  
1813 dependent on a product being marketed. Literature searches should be conducted for all products with  
1814 a marketing authorisation, irrespective of commercial status. It would therefore be expected that  
1815 literature searching would start on submission of a marketing authorisation application and continue  
1816 while the authorisation is active.

1817 ***VI.App2.2. Where to look***

1818 Articles relevant to the safety of medicinal products are usually published in well-recognised scientific  
1819 and medical journals, however, new and important information may be first presented at international  
1820 symposia or in local journals. Although the most well-known databases (e.g. Medline) cover the  
1821 majority of scientific and medical journals, the most relevant publications may be collated elsewhere in  
1822 very specialised medical fields, for certain types of product (e.g. herbal medicinal products) or where  
1823 safety concerns are subject to non-clinical research. A marketing authorisation holder should establish  
1824 the most relevant source of published literature for each product.

1825 Medline, Embase and Excerpta Medica are often used for the purpose of identifying ICSRs. These  
1826 databases have broad medical subject coverage. Other recognised appropriate systems may be used.  
1827 The database providers can advise on the sources of records, the currency of the data, and the nature  
1828 of database inclusions. It is best practice to have selected one or more databases appropriate to a  
1829 specific product. For example, in risk-benefit assessment, safety issues arising during non-clinical  
1830 safety studies may necessitate regular review of a database that has a less clinical focus and includes  
1831 more laboratory-based publications.

1832 Relevant published abstracts from meetings and draft manuscripts should be reviewed for reportable  
1833 ICSRs and for inclusion in periodic safety update reports. Although it is not a requirement for  
1834 marketing authorisation holders to attend all such meetings, if there are company personnel at such a  
1835 meeting, or it is sponsored by a marketing authorisation holder, it is expected that articles of relevance  
1836 would be available to the marketing authorisation holder's pharmacovigilance system. In addition,  
1837 literature that is produced or sponsored by a marketing authorisation holder should be reviewed, so  
1838 that any reportable ICSRs can be reported as required in advance of publication.

1839 If ICSRs are brought to the attention of a marketing authorisation holder from this source, they should  
1840 be processed in the same way as ICSRs found on searching a database or reviewing a journal.

1841 Abstracts from major scientific meetings are indexed and available in some databases, but posters and  
1842 communications are rarely available from this source.

### 1843 **VI.App2.3. Database Searches**

1844 A search is more than a collection of terms used to interrogate a database. Decisions about the  
1845 database selection, approach to records retrieval, term or text selection and the application of limits  
1846 need to be relevant to the purpose of the search. For searches in pharmacovigilance, some of the  
1847 considerations for database searching are described below.

#### 1848 **VI.App2.3.1. Precision and recall**

1849 Medical and scientific databases are a collection of records relating to a set of publications. For any  
1850 given record, each database has a structure that facilitates the organisation of records and searching  
1851 by various means, from simple text to complex indexing terms with associated subheadings. Search  
1852 terms (text or indexed) can be linked using Boolean operators and proximity codes to combine  
1853 concepts, increasing or decreasing the specificity of a search. In addition, limits to the output can be  
1854 set. When searching, the application of search terms means that the output is less than the entire  
1855 database of the records held. The success of a search can be measured according to precision and  
1856 recall (also called sensitivity). Recall is the proportion of records retrieved ("hits") when considering  
1857 the total number of relevant records that are present in the database. Precision is the proportion of  
1858 "hits" that are relevant when considering the number of records that were retrieved. In general, the  
1859 higher recall searches would result in low precision.

#### 1860 **VI.App2.3.2. Search construction**

1861 Databases vary in structure, lag time in indexing and indexing policy for new terms. While some  
1862 database providers give information about the history of a particular indexing term or the application  
1863 of synonyms, other databases are less sophisticated. In addition, author abstracts are not always  
1864 consistent in the choice of words relating to pharmacovigilance concepts or medicinal products/active  
1865 substances names.

1866 When constructing a search for pharmacovigilance, the highest recall for a search would be to enter  
1867 the medicinal product name and active substance name (in all their variants) only. In practice,  
1868 additional indexing terms and text are added to increase precision and to reduce the search result to  
1869 return records that are of relevance to pharmacovigilance. There is a balance to be achieved. It is,  
1870 therefore, expected that complicated searches are accompanied by initial testing to check that relevant  
1871 records are not omitted, however, there is no defined acceptable loss of recall when searching for  
1872 pharmacovigilance purposes. Term selection should be relevant to the database used and the subject  
1873 of the search.

#### 1874 **VI.App2.3.3. Selection of product terms**

1875 Searches should be performed to find records for active substances and not for brand names only. This  
1876 can also include excipients or adjuvants that may have a pharmacological effect. When choosing  
1877 search terms for medicinal products, there are a number of considerations.

- 1878 • Is the active substance an indexed term?
- 1879 • What spellings might be used by authors (particularly if the active substance is not indexed)?

1880 • What alternative names might apply (numbers or codes used for products newly developed,  
1881 chemical names, brand names, active metabolites)?

1882 • Is it medically relevant to search only for a particular salt or specific compound for an active  
1883 substance?

1884 During searches for ICSRs, it may be possible to construct a search that excludes records for  
1885 pharmaceutical forms or routes of administration different to that of the subject product, however,  
1886 restrictions should allow for the inclusion of articles where this is not specified. Search construction  
1887 should also allow for the retrieval of overdose, medication error, abuse, misuse, off-label use or  
1888 occupational exposure information, which could be poorly indexed. Searches should also not routinely  
1889 exclude records of unbranded products or records for other company brands.

#### 1890 **VI.App2.3.4. Selection of search terms**

1891 As described previously, there is no acceptable loss of recall when searching published literature for  
1892 pharmacovigilance. The use of search terms (free text or use of indexing) to construct more precise  
1893 searches may assist in managing the output. Deficiencies that have been found frequently during  
1894 Competent Authority inspections include:

1895 • the omission of outcome terms, for example "death" as an outcome may be the only indexed term  
1896 in a case of sudden death;

1897 • the omission of pregnancy terms to find adverse outcomes in pregnancy for ICSR reporting;

1898 • the omission of terms to include special types of reports which needs to be addressed as well in  
1899 periodic safety update reports, for example,

1900 – Reports of asymptomatic overdose, medication error, off-label use, misuse, abuse,  
1901 occupational exposure;

1902 – Reports of uneventful pregnancy.

#### 1903 **VI.App2.3.5. Limits to a search**

1904 Some databases apply indexing that allows the application of limits to a search, for example by subject  
1905 age, sex, publication type. The limits applied to a search are not always shown in the "search strategy"  
1906 or search string.

1907 If limits are applied, they should be relevant to the purpose of the search. When searching a worldwide  
1908 scientific and medical literature database, titles and abstracts are usually in English language. The use  
1909 of limits that reduce the search result to only those published in the English language is generally not  
1910 acceptable. Limits applied to patient types, or other aspects of an article, for example human, would  
1911 need to be justified in the context of the purpose of a search.

1912 Limits can be applied to produce results for date ranges, for example, weekly searches can be obtained  
1913 by specifying the start and end date for the records to be retrieved. Care should be taken to ensure  
1914 that the search is inclusive for an entire time period, for example, records that may have been added  
1915 later in the day for the day of the search should be covered in the next search period. The search  
1916 should also retrieve all records added in that period, and not just those initially entered or published  
1917 during the specified period (so that records that have been updated or retrospectively added are  
1918 retrieved). This should be checked with the database provider if it is not clear.

1919 Although one of the purposes of searching is to identify ICSRs for reporting, the use of publication type  
1920 limits is not robust. ICSRs may be presented within review or study publications, and such records may

1921 not be indexed as "case-reports", resulting in their omission for preparation of periodic safety update  
1922 reports from search results limited by publication type.

#### 1923 ***VI.App2.4. Record keeping***

1924 Records of literature searches should be maintained in accordance with the requirements described in  
1925 [IR Art 12]. Marketing authorisation holders should demonstrate due diligence in searching published  
1926 scientific and medical literature. It is always good practice to retain a record of the search construction,  
1927 the database used and the date the search was run. In addition, it may be useful to retain results of  
1928 the search for an appropriate period of time, particularly in the event of zero results. If decision  
1929 making is documented on the results, it is particularly important to retain this information.

#### 1930 ***VI.App2.5. Outputs***

1931 Databases can show search results in different ways, for example, titles only or title and abstract with  
1932 or without indexing terms. Some publications are of obvious relevance at first glance, whereas others  
1933 may be more difficult to identify. Consistent with the requirement to provide the full citation for an  
1934 article and to identify relevant publications, the title, citation and abstract (if available) should always  
1935 be retrieved and reviewed.

#### 1936 ***VI.App2.6. Review and selection of articles***

1937 It is recognised that literature search results are a surrogate for the actual article. Therefore, it is  
1938 expected that the person reviewing the results of a search is trained to identify the articles of  
1939 relevance. This may be an information professional trained in pharmacovigilance or a  
1940 pharmacovigilance professional with knowledge of the database used. Recorded confirmation that the  
1941 search results have been reviewed will assist in demonstrating that there is a systematic approach to  
1942 collecting information about suspected adverse reactions from literature sources. It is recommended  
1943 that quality control checks are performed on a sample of literature reviews / selection of articles to  
1944 check the primary reviewer is identifying the relevant articles.

1945 A common issue in selecting relevant articles from the results of a search is that often this process is  
1946 conducted for the purposes of identification of ICSRs only. Whereas the review should also be used as  
1947 the basis for collating articles for the periodic safety update report production, therefore relevant  
1948 studies with no ICSRs should also be identified, as well as those reports of events that do not qualify  
1949 for reporting.

1950 Outputs from searches may contain enough information to be a valid ICSR, in which case the article  
1951 should be ordered. All articles for search results that are likely to be relevant to pharmacovigilance  
1952 requirements should be obtained, as they may contain valid ICSRs or relevant safety information. The  
1953 urgency with which this occurs should be proportionate to the content of the material reviewed and the  
1954 resulting requirement for action as applicable for the marketing authorisation holder.

1955 Articles can be excluded from reporting by the marketing authorisation holder if another company's  
1956 branded medicinal product is the suspected medicinal product. In the absence of a specified medicinal  
1957 product source and/or invented name, ownership of the medicinal product should be assumed for  
1958 articles about an active substance. Alternative reasons for the exclusion of a published article for the  
1959 reporting of ICSRs are detailed in [VI.C.2.2.3.](#)



1960 **VI.App2.7. Day zero**

1961 As described in [VI.B.7.](#), day zero is the date on which an organisation becomes aware of a publication  
1962 containing the minimum information for an ICSR to be reportable. Awareness of a publication includes  
1963 any personnel of that organisation, or third parties with contractual arrangements with the  
1964 organisation. It is sometimes possible to identify the date on which a record was available on a  
1965 database, although with weekly literature searching, day zero for a reportable adverse reaction present  
1966 in an abstract is taken to be the date on which the search was conducted. For articles that have been  
1967 ordered as a result of literature search results, day zero is the date when the minimum information for  
1968 an ICSR to be valid is available. Organisations should take appropriate measures to obtain articles  
1969 promptly in order to confirm the validity of a case.

1970 **VI.App2.8. Duplicates**

1971 Consistent with the requirements for reporting ICSRs, literature cases should be checked to prevent  
1972 reporting of duplicates, and previously reported cases should be identified as such when reported. It is,  
1973 therefore, expected that ICSRs are checked in the organisation database to identify literature articles  
1974 that have already been reported.

1975 **VI.App2.9. Contracting out Literature Search Services**

1976 It is possible to use the services of another party to conduct searches of the published scientific and  
1977 medical literature. In this event, the responsibility for the performance of the search and subsequent  
1978 reporting still remains. The transfer of a pharmacovigilance task or function should be detailed in a  
1979 contract between the organisation and the service provider. The nature of third party arrangements for  
1980 literature searching can range from access to a particular database interface only (access to a  
1981 technology) to full literature searching, review and reporting (using the professional pharmacovigilance  
1982 services of another organisation). It is recognised that more than one organisation may share services  
1983 of a third party to conduct searches for generic active substances. In this instance, each organisation  
1984 should satisfy itself that the search and service is appropriate to their needs and obligations.

1985 Where an organisation is dependent on a particular service provider for literature searching, it is  
1986 expected that an assessment of the service(s) is undertaken to determine whether it meets the needs  
1987 and obligations of the organisation. In any case, the arrangement should be clearly documented.

1988 The clock start for the reporting of ICSRs begins with awareness of the minimum information by either  
1989 the organisation or the contractual partner (whichever is the earliest). This also applies where a third  
1990 party provides a review or a collated report from the published scientific and medical literature, in  
1991 order to ensure that published literature cases are reported as required within the correct time frames.  
1992 That is, day zero is the date the search was run if the minimum criteria are available in the abstract  
1993 and not the date the information was supplied to the organisation.

1994 **VI.App2.10. Electronic submission of copies of articles published in the**  
1995 **scientific and medical literature**

1996 Until standards for the electronic transmission of attachments (e.g. copies of literature articles) are  
1997 developed in the framework of ICH, the sender should follow the rules outlined below for the  
1998 submission of a copy of the literature article as detailed in [VI.C.6.2.3.2.](#):

1999 1. Mailing address and format of literature articles:

- 2000 Literature articles reportable to the Agency should be provided in PDF format and sent via e-mail to  
2001 the following e-mail address: [EVLIT@ema.europa.eu](mailto:EVLIT@ema.europa.eu).
- 2002 In relation to copies of articles from the published scientific and medical literature, marketing  
2003 authorisation holders are recommended to consider potential copyright issues specifically as  
2004 regards the electronic transmission and handling of electronic copies in the frame of regulatory  
2005 activities.
- 2006 2. File name of literature articles sent in electronic format to the Agency:
- 2007 The file name of a literature article sent in PDF format should match exactly the 'World-Wide  
2008 Unique Case Identification Number' (ICH-E2B(R2) A.1.10.1 or A.1.10.2 as applicable) assigned to  
2009 the individual case, which is described in the article and which is reported in the E2B(R2) ICSR  
2010 format.
- 2011 If there is a follow-up article to the individual case published in the literature, the file name with  
2012 the World-Wide Unique Case Identification Number must be maintained but should include a  
2013 sequence number separated with a dash.
- 2014 Examples:
- 2015 • Initial ICSR published in the literature: FR-ORGABC-23232321 (data element 'World-Wide Unique  
2016 Case Identification Number' (ICH-E2B(R2) A.1.10.1));
- 2017 – File name of the literature article: FR-ORGABC-23232321.pdf.
- 2018 • Follow-up information published in the literature in a separate article:
- 2019 – ICSR: FR-ORGABC-23232321 (data element World-Wide Unique Case Identification Number  
2020 remains unchanged (ICH-E2B(R2) A.1.10.1));
- 2021 – File name: FR-ORGABC-23232321-1.pdf.
- 2022 3. Reporting of cases reported in the scientific and medical literature referring to more than one  
2023 patient:
- 2024 When the literature article refers to the description of more than one patient, the copy of the  
2025 literature article should be sent only once.
- 2026 The file name of a literature article sent in PDF format should match exactly the 'World-Wide  
2027 Unique Case Identification Number' (data element ICH-E2B(R2) A.1.10.1 or A.1.10.2 as applicable)  
2028 assigned to the first reportable individual case described in the article.
- 2029 In addition, all ICSRs which relate to the same literature article should be cross referenced in the  
2030 data element 'Identification number of the report which is linked to this report' (ICH-E2B(R2)  
2031 A.1.12). The data element should be repeated as necessary to cross refer all related cases (see  
2032 Table VI.2).

**Table VI.2.** Examples for the reporting of ICSRs described in the scientific and medical literature and referring to more than one patient

| Ex. | Scenario  | Action   |
|-----|---|--|
| 1   | <p>A literature article describes suspected adverse reactions that have been experienced by up to 3 single patients.</p> <p>3 ICSRs should be created and reported for each individual identifiable patient described in the literature article.</p> <p>Each ICSR should contain all the available information on the case.</p> | <p>For Case 1 described in the literature article:</p> <ul style="list-style-type: none"> <li>• ICH-E2B(R2) A.1.10.1 'World-Wide Unique Case Identification Number':<br/>UK-ORGABC-0001</li> <li>• ICH-E2B(R2) A.1.12 'Identification number of the report which is linked to this report':<br/>UK-ORGABC-0002</li> <li>• ICH-E2B(R2) A.1.12 'Identification number of the report which is linked to this report':<br/>UK-ORGABC-0003</li> <li>• ICH-E2B(R2) A.2.2 'Literature reference(s):<br/>Literature reference in line with uniform requirements for manuscripts submitted to biomedical journals:<br/>N Engl J Med. 1997;336:309-15.</li> <li>• File name for the copy of literature article to be sent via e-mail to EVLIT@ema.europa.eu:<br/>UK-ORGABC-0001.pdf</li> </ul> <p>For Case 2 described in the literature article:</p> <ul style="list-style-type: none"> <li>• ICH-E2B(R2) A.1.10.1 'World-Wide Unique Case Identification Number':<br/>UK-ORGABC-0002</li> <li>• ICH-E2B(R2) A.1.12 'Identification number of the report which is linked to this report':<br/>UK-ORGABC-0001</li> <li>• ICH-E2B(R2) A.1.12 'Identification number of the report which is linked to this report':<br/>UK-ORGABC-0003</li> <li>• ICH-E2B(R2) A.2.2 'Literature reference(s):<br/>Literature reference in line with uniform requirements for manuscripts submitted to biomedical journals:<br/>N Engl J Med. 1997;336:309-15.</li> <li>• No copy of the literature article required since the copy was already submitted for case 1.</li> </ul> <p>For Case 3 described in the literature article:</p> <ul style="list-style-type: none"> <li>• ICH-E2B(R2) A.1.10.1 'World-Wide Unique Case Identification Number':<br/>UK-ORGABC-0003</li> <li>• ICH-E2B(R2) A.1.12 'Identification number of the report which is linked to this report':<br/>UK-ORGABC-0001</li> <li>• ICH-E2B(R2) A.1.12 'Identification number of the report which is linked to this report':<br/>UK-ORGABC-0002</li> </ul> |

| Ex. | Scenario  | Action   |
|-----|---|--|
|     |   | <ul style="list-style-type: none"> <li>• ICH-E2B(R2) A.2.2 'Literature reference(s): Literature reference in line with uniform requirements for manuscripts submitted to biomedical journals: N Engl J Med. 1997;336:309-15.</li> <li>• No copy of the literature article required since the copy was already submitted for case 1.</li> </ul>   |
| 2   | <p>A literature article describes suspected adverse reactions that have been experienced by more than 3 single patients.</p> <p>ICSRs should be created and reported for each individual identifiable patient described in the literature article.</p> <p>Each ICSR should contain all the available information on the case.</p> <p>The cross reference with all the linked ICSRs from this literature article should only be provided in the first case, in the data element ICH-E2B(R2) A.1.12 'Identification number of the report which is linked to this report'. There is no need to repeat all the cross references in the other ICSRs.</p> | <p>For the ICSRs which relate to the same literature article, the cross reference in the data element 'Identification number of the report which is linked to this report' ICH (E2B(R2) field A.1.12) should be conducted as follows:</p> <ul style="list-style-type: none"> <li>• The first case should be linked to all other cases related to the same article;</li> <li>• All the other cases should be only linked to the first one, as in the example below.</li> </ul> <p><i>Example for the reporting of cases originally reported in the scientific and medical literature referring to a large number of patients:</i></p> <p>For Case 1 described in the literature article:</p> <ul style="list-style-type: none"> <li>• ICH E2B(R2) A.1.10.1 'Worldwide Unique Case Identification Number': UK-ORGABC-0001</li> <li>• ICH-E2B(R2) A.1.12 'Identification number of the report which is linked to this report': UK-ORGABC-0002</li> <li>• ICH-E2B(R2) A.1.12 'Identification number of the report which is linked to this report': UK-ORGABC-0003</li> <li>• ICH-E2B(R2) A.1.12 'Identification number of the report which is linked to this report': UK-ORGABC-0004</li> <li>• ICH-E2B(R2) A.1.12 'Identification number of the report which is linked to this report': UK-ORGABC-000N</li> <li>• ICH-E2B(R2) A.2.2 'Literature reference(s)': N Engl J Med. 1997;336:309-15.</li> <li>• File name for the copy of literature article to be sent via e-mail to EVLIT@ema.europa.eu: UK-ORGABC-0001.pdf.</li> </ul> <p>For Case 2 described in the literature article:</p> <ul style="list-style-type: none"> <li>• ICH E2B(R2) A.1.10.1 'Worldwide Unique Case Identification Number': UK-ORGABC-0002</li> <li>• ICH-E2B(R2) A.1.12 'Identification number of the report which is linked to this report': UK-ORGABC-0001</li> <li>• ICH-E2B(R2) A.2.2 'Literature reference(s)':</li> </ul> |

| Ex. | Scenario | Action   |
|-----|----------|--|
|     |          | <p>N Engl J Med. 1997;336:309-15.</p> <ul style="list-style-type: none"> <li>No copy of the literature article required since the copy was already submitted for case 1.</li> </ul> <p>For Case N described in the literature article:</p> <ul style="list-style-type: none"> <li>ICH-E2B(R2) A.1.10.1 'Worldwide Unique Case Identification Number':<br/>UK-ORGABC-000N</li> <li>ICH-E2B(R2) A.1.12 'Identification number of the report which is linked to this report':<br/>UK-ORGABC-0001</li> <li>ICH-E2B(R2) A.2.2 'Literature reference(s)':<br/>N Engl J Med. 1997;336:309-15.</li> <li>No copy of the literature article required since the copy was already submitted for case 1.</li> </ul> |

2035

2036 **VI.Appendix 3 Modalities for reporting**

2037 **VI.App3.1. Interim arrangements**

2038 **Figure VI.3.** Business process map - Suspected adverse reaction reporting in EU – Interim  
 2039 arrangements

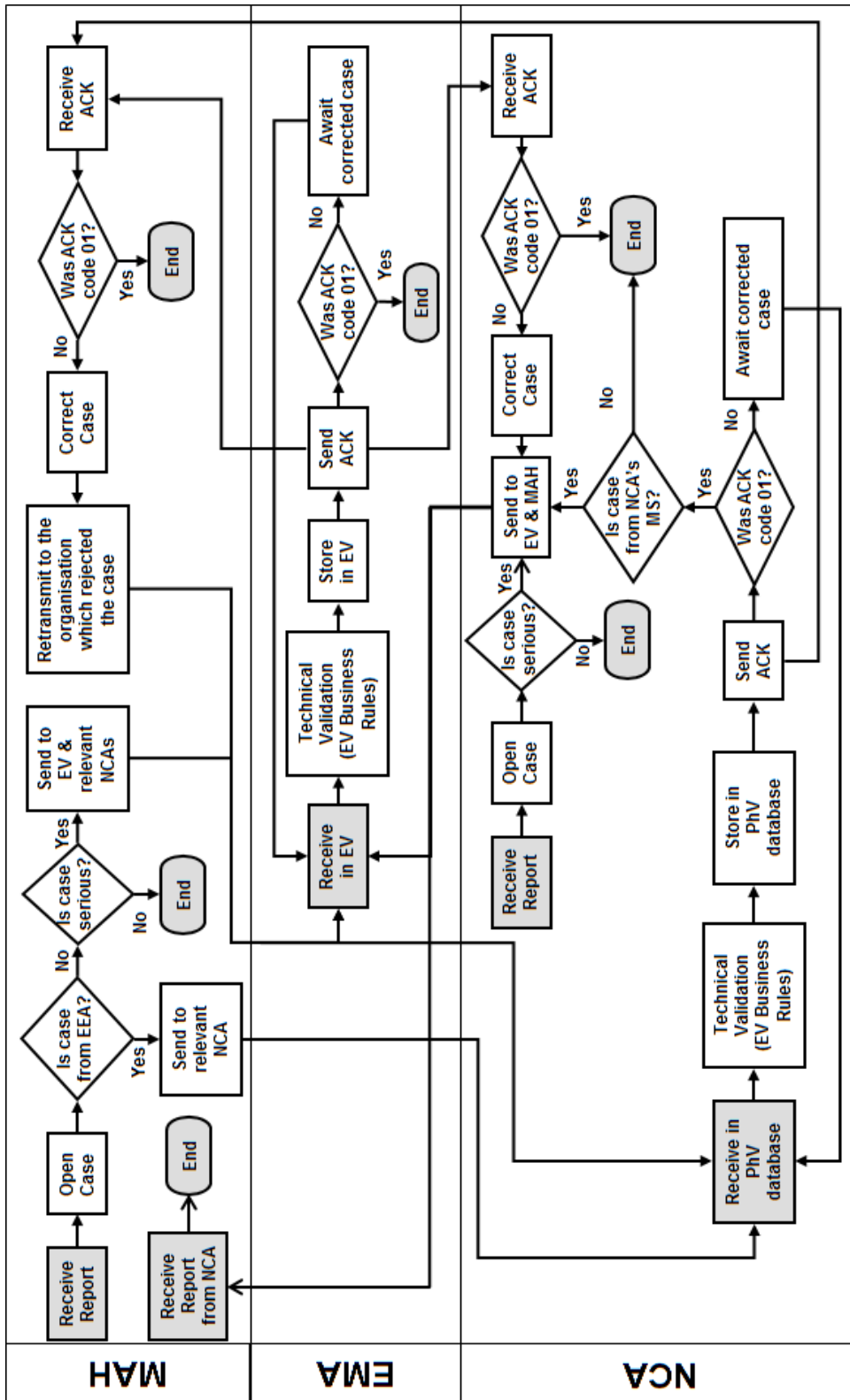

2040

2041 **Table VI.3.** Process description - Suspected adverse reaction reporting in EU - Interim arrangements

| No. | Step                                      | Description   | Responsible Organisation |
|-----|---|---|--------------------------|
| 1   | <b>Start.</b><br><b>Receive report.</b>   | <b>Marketing Authorisation Holder (MAH) receives information on a suspected adverse reaction from a patient, healthcare professional or other valid reporter. If the case has been received from an EU NCA, <u>do not retransmit it to EudraVigilance (EV).</u></b>   | <b>MAH</b>               |
| 2   | Open case.                                | Open and create an individual case safety report.   | MAH                      |
| 3   | Is case from EEA?                         | Did the adverse reactions occur in the EU?<br>If No, go to step 3.1.<br>If Yes, got so step 5.  | MAH                      |
| 3.1 | Is case serious?                          | If No, go to step 3.2.<br>If Yes, got to step 4.  | MAH                      |
| 3.2 | <b>End.</b>                               | <b>The case is now stored in the MAHs pharmacovigilance database. Normal follow-up activities should continue and if any follow-up is received, return to step 1.</b>   | <b>MAH</b>               |
| 4   | Send to EV & relevant NCAs.               | Transmit the serious case electronically, in ICH E2B(R2) format as an xml message within the 15-day time frame to EV and to the relevant NCAs, where required. The case goes to step 4.1 & step 6.  | MAH                      |
| 4.1 | <b>Receive in EV.</b>                     | Receive the message in EV database from MAH or NCA.   | <b>EMA</b>               |
| 4.2 | Technical Validation (EV Business Rules). | Every message that is received in EV is validated against the EudraVigilance Business Rules and an Acknowledgement message (ACK) is created specifying whether or not the message & the case(s) therein are valid.<br>A valid message will have an ACK code 01. A non-valid message will have an ACK code 02 (if a case contained therein is non-valid) or 03 (if the message itself is not correctly formatted). | EMA                      |
| 4.3 | Store in EV.                              | Once the case has been validated, it is stored in EV.   | EMA                      |
| 4.4 | Send ACK.                                 | The acknowledgement message created in step 4.2 is transmitted to the case sender, no later than 2 business days following receipt of the case.<br>Go to step 16 for MAHs receiving the ACK.<br>Go to step 20 for NCAs receiving the ACK.   | EMA                      |

| No. | Step  | Description  | Responsible Organisation |
|-----|---|--|--------------------------|
|     |   | Go to step 4.5 for the EMA's next step.  |                          |
| 4.5 | Was ACK code 01?                                    | If No, go to step 4.6.<br>If Yes, go to step 4.7.  | EMA                      |
| 4.6 | Await corrected case.                               | The sender should correct every case with an error ACK and retransmit within the regulatory reporting timelines. Periodically the EMA should assess all cases with an error ACK for which a corrected case has not been transmitted and contact the Qualified Person responsible for Pharmacovigilance (QPPV) to inform of these missing corrected cases. If a sender fails to correct cases, then this information should be incorporated into data quality assessments and the appropriate committees should be informed.<br><br>Go back to step 4.1 upon receipt of the corrected case. | EMA                      |
| 4.7 | End.  | <b>The case is now stored in EV &amp;, following duplicate detection &amp; recoding will be available for signal detection and data quality analyses.</b>  | EMA                      |
| 5   | <b>Send to relevant NCA.</b>                        | Transmit the case (serious, and if required non-serious) electronically, in ICH E2B(R2) format as an xml message within the relevant time frames (15 or 90 days, as applicable), to the relevant NCA for the Member State where the reaction occurred. If country of occurrence has not been specified, then country of primary source should normally be taken to be the occurrence country.  | MAH                      |
| 6   | <b>Receive in Pharmacovigilance (PhV) database.</b> | Receive the message from MAH in the NCA's PhV database.  | NCA                      |
| 7   | Technical Validation (EV Business Rules).           | Every message that is received in the NCA's PhV database should be validated against the EudraVigilance Business Rules and an Acknowledgement message (ACK) is created specifying whether or not the message & the case(s) therein are valid. A valid message will have an ACK code 01. A non-valid message will have an ACK code 02 (if a case contained therein is non-valid) or 03 (if the message itself is  | NCA                      |



| No.  | Step                                    | Description  | Responsible Organisation |
|------|---|--|--------------------------|
|      |   | not correctly formatted).  |                          |
| 8    | Store in EV.                            | Once the case has been validated, it is stored in the NCA's PhV database.  | NCA                      |
| 9    | Send ACK.                               | The acknowledgement message created in step 7 is transmitted to the case sender no later than 2 business days following receipt of the case.<br>Go to step 16 for MAHs receiving the ACK.<br>Go to step 10 for the NCA's next step.  | NCA                      |
| 10   | Was ACK code 01?                        | If No, go to step 10.1.<br>If Yes, go to step 11.  | NCA                      |
| 10.1 | Await corrected case.                   | The MAH should correct every case with an error ACK and retransmit it within the regulatory reporting timelines. Periodically the NCA should assess all cases with an error ACK for which a corrected case has not been transmitted and contact the QPPV to inform them of these missing corrected cases. If a sender fails to correct cases, then this information should be incorporated into any data quality assessments performed and the appropriate action can be taken.<br>Go back to step 6 upon receipt of the corrected case. | NCA                      |
| 11   | Was case from NCA's MS?                 | Did the case occur in the territory of the receiving NCA?<br>If No, go to step 11.1.<br>If Yes, go to step 12.   | NCA                      |
| 11.1 | <b>End.</b>                             | <b>The case is now stored in the NCA's pharmacovigilance database &amp;, following duplicate detection &amp; recoding will be available for signal detection and data quality analyses.</b>  | <b>NCA</b>               |
| 12   | Send to EV & MAH.                       | Transmit the serious case electronically, in ICH E2B(R2) format as an xml message within the 15-day time frame to EV and to the relevant MAH(s).<br>Go to step 4.1 for reception of the case in EV<br>Go to step 24 for reception of the case by the relevant MAH(s)   | NCA                      |
| 13   | <b>Start.</b><br><b>Receive report.</b> | <b>NCA receives information on a suspected adverse reaction from a patient, healthcare professional or other valid reporter concerning a</b>   | <b>NCA</b>               |

| No.         | Step  | Description   | Responsible Organisation |
|-------------|---|---|--------------------------|
|             |   | <b>suspected adverse reaction occurring in the territory of the receiving competent authority.</b>  |                          |
| 14          | Open case.  | Open and create an individual case safety report.   | NCA                      |
| 15          | Is case serious?  | If No, go to step 15.1<br>If Yes, go to step 12   | NCA                      |
| 15.1        | <b>End</b>  | <b>The case is now stored in the NCA's pharmacovigilance database &amp;, following duplicate detection &amp; recoding will be available for signal detection and data quality analyses.</b>   | NCA                      |
| <b>16</b>   | <b>Receive ACK.</b>                                     | Receive the ACK message, associate it with the relevant case(s) and check to ensure that the case was considered valid.   | <b>MAH</b>               |
| 17          | Was ACK code 01?  | If yes, go to step 17.1.<br>If no, then the regulatory timeline clock has not stopped and the case should be corrected and re-transmitted to EV within the relevant regulatory reporting timelines. Day 0 remains as the day that the first information was received. A 02 or 03 ACK does not constitute new information. Go to step 18 (Correct case). | MAH                      |
| <b>17.1</b> | <b>End.</b>   | <b>End the process of transmitting this version of the case to EV or NCA. Normal follow-up activities should continue and if any follow-up is received, return to step 1.</b>   | <b>MAH</b>               |
| 18          | Correct case.   | Correct the case to remove the errors identified in the ACK.  | MAH                      |
| 19          | Retransmit to the organisation which rejected the case. | Retransmit the corrected case to the organisation which rejected the case with ACK code 02 or 03.<br>Got to step 4.1 &/or step 6 as appropriate.  | MAH                      |
| <b>20</b>   | <b>Receive ACK.</b>                                     | Receive the ACK message, associate it with the relevant case(s) and check to ensure that the case was considered valid.   | <b>NCA</b>               |
| 21          | Was ACK code 01?  | If yes, go to step 23.<br>If no, then the regulatory timeline clock has not stopped and the case should be corrected and re-transmitted to EV within the relevant regulatory reporting  | NCA                      |

| No. | Step                    | Description   | Responsible Organisation |
|-----|-------------------------|---|--------------------------|
|     |                         | timelines. Day 0 remains as the day that the first information was received. A 02 or 03 ACK does not constitute new information. Go to step 22 (Correct case).  |                          |
| 22  | Correct case.           | Correct the case to remove the errors identified in the ACK and retransmit the case to EV and to the relevant MAH(s) (go back to step 12).  | NCA                      |
| 23  | End.                    | <b>End the process of transmitting this version of the case to EV and to the relevant MAH(s). Normal follow-up activities should continue and if any follow-up is received, return to step 6 or 13.</b> | NCA                      |
| 24  | Receive report from NCA | MAH receives information on a suspected adverse reaction from an NCA.<br><b>This case should not be retransmitted to EV and to the NCA which transmitted it to the MAH</b>                              | MAH                      |
| 25  | End                     | <b>The case is now stored in the MAH's pharmacovigilance database &amp; following duplicate detection &amp; recoding will be available for signal detection and data quality analyses.</b>              | MAH                      |

2042

2043 **VI.App3.1.1. Interim arrangements applicable to marketing authorisation**  
 2044 **holders**

2045 Reporting requirements of ICSRs applicable to marketing authorisation holders during the interim  
 2046 period are detailed in the latest version of Doc. EMA/321386/2012 available on EMA website under the  
 2047 following pathway: [Home/Regulatory/Human medicines/Pharmacovigilance /2010 pharmacovigilance](#)  
 2048 [legislation/Q&A on implementation](#)

2049 **Table VI.4.** Reporting requirements applicable to marketing authorisation holders – Interim  
 2050 arrangements

| Marketing authorisation procedure  | Origin | Adverse reaction type | Destination  | Time frame |
|--|--------|-----------------------|--|------------|
| <ul style="list-style-type: none"> <li>• Centralised</li> <li>• Mutual recognition, decentralised or subject to referral</li> <li>• Purely national</li> </ul> | EU     | All serious           | Member State <sup>(1)</sup> where suspected adverse reaction occurred  | 15 days    |
|  |        | All non-serious       | Member State where suspected adverse reaction occurred, if required (See Table VI.5)   | 90 days    |
|  | Non-EU | All serious           | <ul style="list-style-type: none"> <li>• EudraVigilance database</li> <li>• Member States where suspected medicinal product is authorised, if required (See Table VI.5)</li> </ul> | 15 days    |

2051 <sup>(1)</sup> Member States may request marketing authorisation holders to report those cases to EudraVigilance.  
 2052 This will be further addressed in a specific question and answer document.

2053 **Table VI.5.** Reporting requirements applicable to marketing authorisation holders – Interim  
 2054 arrangements – Member States requirements

| Marketing authorisation procedure  | Origin | Adverse reaction type | Destination  | YES  | NO  |
|--|--------|-----------------------|--|--|---|
| <ul style="list-style-type: none"> <li>• Centralised</li> <li>• Mutual recognition, decentralised or subject to referral</li> <li>• Purely national</li> </ul> | EU     | All non-serious       | Member State where suspected adverse reaction occurred | AT,<br>DE <sup>1</sup> ,<br>DK,<br>IS, PL,<br>RO | BE, BG, CY, CZ,<br>DE, EE, ES, FI,<br>FR, GR, HU, IE,<br>IT, LI, LT, LU, LV,<br>MT, NL, NO, PT,<br>SE, SI, SK, UK |

| Marketing authorisation procedure | Origin | Adverse reaction type | Destination   | YES        | NO   |
|-----------------------------------|--------|-----------------------|---|------------|--|
|                                   | Non-EU | All serious           | Member States where suspected medicinal product is authorised | DE, SK, UK | AT, BE, BG, CY, CZ, DK, EE, ES, FI, FR, GR, HU, IE, IS, IT, LI, LT, LU, LV, MT, NL, NO, PL, PT, RO, SE, SI |

2055 DE<sup>1</sup>: Only for non-serious cases related to vaccines reportable to the Paul Ehrlich Institut. Reporting of  
2056 other non-serious cases related to non-vaccines medicinal products will only be requested individually  
2057 in case of safety concerns.

2058 **VI.App3.1.2. Interim arrangements applicable to competent authorities in**  
 2059 **Member States**

2060 **Table VI.4.** Reporting requirements applicable to competent authorities in Member States - Interim  
 2061 arrangements

| Marketing authorisation procedure  | Origin | Adverse reaction type | Destination  | Time frame |
|--|--------|-----------------------|--|------------|
| <ul style="list-style-type: none"> <li>Centralised</li> <li>Mutual recognition, decentralised or subject to referral</li> <li>Purely national</li> </ul> | EU     | All serious           | <ul style="list-style-type: none"> <li>EudraVigilance database</li> <li>Marketing authorisation holder of the suspected medicinal product</li> </ul> | 15 days    |

2062

2063 **VI.App3.2. Final arrangements**

2064 **Figure VI.4.** Business process map - Suspected adverse reaction reporting in EU - Final arrangements

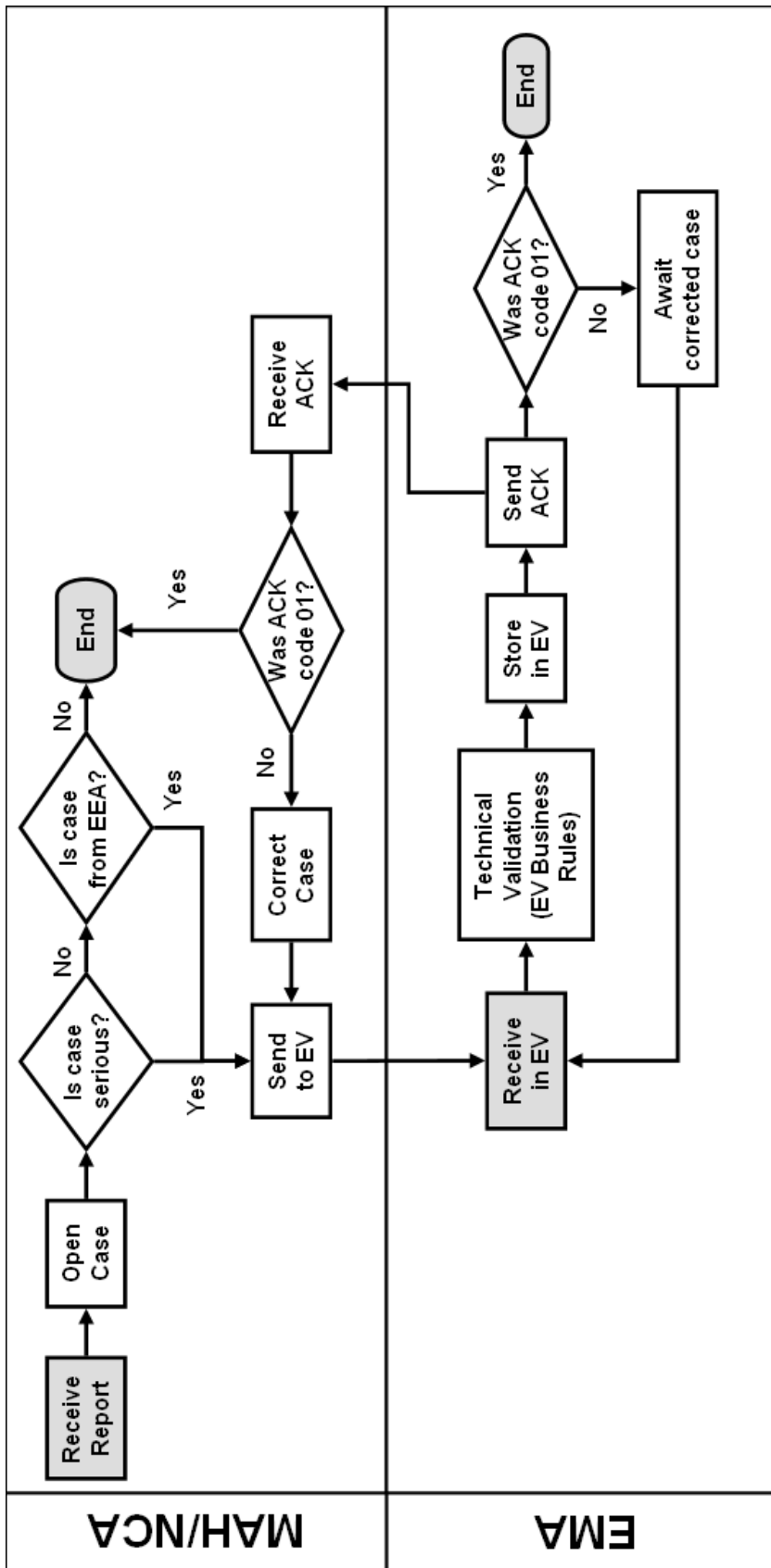

2065

2066 **Table VI.5.** Process description - Suspected adverse reaction reporting in EU - Final arrangements

| No. | Step                                      | Description   | Responsible Organisation |
|-----|---|---|--------------------------|
| 1   | <b>Start.<br/>Receive report.</b>         | <b>National Competent Authority (NCA) or Marketing Authorisation Holder (MAH) receives information on a suspected adverse reaction from a patient, healthcare professional or other valid reporter.<br/>If the case has been received from an EU NCA, <u>do not</u> retransmit it to EudraVigilance (EV).</b>   | <b>MAH/NCA</b>           |
| 2   | Open case.                                | Open and create an individual case safety report.   | MAH/NCA                  |
| 3   | Is case serious?                          | If No go to step 3.1.<br>If Yes, go to step 4.  |                          |
| 3.1 | Is case from EEA?                         | If No go to step 11.1.<br>If Yes, go to step 4.   |                          |
| 4   | Send to EV.                               | Transmit the case (all serious and EU non-serious) electronically, in ICH E2B(R2) format as an xml message within the relevant time frame (15 or 90 days, as applicable), to EV.  | MAH/NCA                  |
| 5   | <b>Receive in EV.</b>                     | Receive the message in the EV.  | <b>EMA</b>               |
| 6   | Technical Validation (EV Business Rules). | Every message that is received in EV is validated against the EudraVigilance Business Rules and an Acknowledgement message (ACK) is created specifying whether or not the message & the case(s) therein are valid.<br>A valid message will have an ACK code 01. A non-valid message will have an ACK code 02 (if a case contained therein is non-valid) or 03 (if the message itself is not correctly formatted). | EMA                      |
| 7   | Store in EV.                              | Once the case has been validated, it is stored in the EV.   | EMA                      |
| 8   | Send ACK.                                 | The acknowledgement message created in step 6 is transmitted to the case sender no later than 2 business days following receipt of the case.<br>Go to step 9 for the EMA's next step.<br>Go to step 10 for MAH/NCA's next step.   | EMA                      |
| 9   | Was ACK code 01?                          | If No go to step 9.1.<br>If Yes, go to step 9.2.  | EMA                      |
| 9.1 | Await corrected case.                     | The sender should correct every case with an error ACK and retransmit it within the   | EMA                      |



| No.  | Step             | Description  | Responsible Organisation |
|------|------------------|--|--------------------------|
|      |                  | regulatory reporting timelines. Periodically the EMA should assess all cases with an error ACK for which a corrected case has not been transmitted and contact the Qualified Person responsible for Pharmacovigilance (QPPV) to inform these missing corrected cases. If a sender fails to correct cases, this information should be incorporated into data quality assessments and the appropriate committees should be informed. Go back to step 5 upon receipt of the corrected case. |                          |
| 9.2  | End.             | <b>The case is now stored in EV &amp;, following duplicate detection &amp; recoding will be available for signal detection and data quality analyses. If the case occurred in the EU and was transmitted to EV by a MAH, it will be rerouted to the relevant NCA (see <a href="#">VI. Appendix 3.3</a>)</b>  | EMA                      |
| 10   | Receive ACK.     | Receive the ACK message, associate it with the relevant case(s) and check to ensure that the case was considered valid.  | MAH/NCA                  |
| 11   | Was ACK code 01? | If yes, go to step 11.1.<br>If no, then the regulatory timeline clock has not stopped and the case should be corrected and re-transmitted to EV within the relevant regulatory reporting timelines. Day 0 remains as the day that the first information was received. A 02 or 03 ACK does not constitute new information. Go to step 12 (Correct case)   | MAH/NCA                  |
| 11.1 | End.             | <b>End the process for this version of the case. Normal follow-up activities should continue and if any follow-up is received, return to step 1.</b>   | MAH/NCA                  |
| 12   | Correct case.    | Correct the case to remove the errors identified in the ACK and retransmit the case to EV (go back to step 4).   | MAH/NCA                  |

2067

2068 **VI.App3.2.1. Final arrangements applicable to marketing authorisation**  
 2069 **holders**

2070 **Table VI.6.** Reporting requirements applicable to marketing authorisation holders - Final  
 2071 arrangements

| Marketing authorisation procedure   | Origin | Adverse reaction type | Destination   | Time frame |
|---|--------|-----------------------|---|------------|
| <ul style="list-style-type: none"> <li>Centralised</li> <li>Mutual recognition, decentralised or subject to referral</li> </ul> | EU     | All serious           | <ul style="list-style-type: none"> <li>EudraVigilance database</li> </ul> | 15 days    |
|   |        | All non-serious       | <ul style="list-style-type: none"> <li>EudraVigilance database</li> </ul> | 90 days    |
| <ul style="list-style-type: none"> <li>Purely national</li> </ul>   | Non-EU | All serious           | <ul style="list-style-type: none"> <li>EudraVigilance database</li> </ul> | 15 days    |

2072

2073 **VI.App3.2.2. Final arrangements applicable to competent authorities in**  
 2074 **Member States**

2075 **Table VI.7.** Reporting requirements applicable to competent authorities in Member States - Final  
 2076 arrangements

| Marketing authorisation procedure   | Origin | Adverse reaction type | Destination   | Time frame |
|---|--------|-----------------------|---|------------|
| <ul style="list-style-type: none"> <li>Centralised</li> <li>Mutual recognition, decentralised or subject to referral</li> </ul> | EU     | All serious           | <ul style="list-style-type: none"> <li>EudraVigilance database</li> </ul> | 15 days    |
|   |        | All non-serious       | <ul style="list-style-type: none"> <li>EudraVigilance database</li> </ul> | 90 days    |
| <ul style="list-style-type: none"> <li>Purely national</li> </ul>   |        |                       |   |            |

2077  
2078

**VI.App3.3. Transmission and rerouting of ICSRs to competent authorities in Member States**<sup>43</sup>

2079  
2080

**Figure VI.5.** Business process map - Transmission and rerouting of ICSRs to competent authorities in Member States

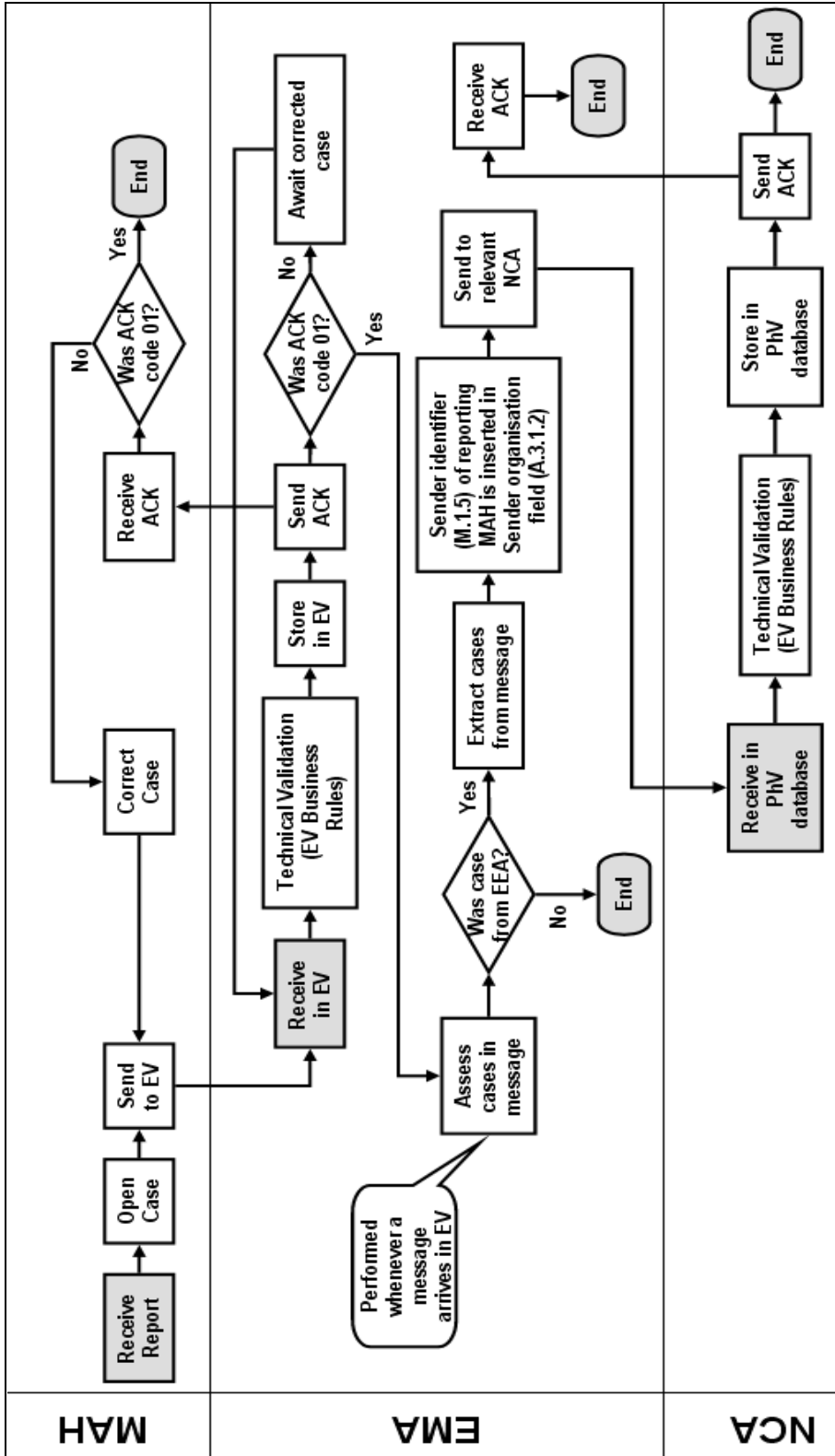

2081

<sup>43</sup> Once the functionalities of the EudraVigilance database specified in [REG Art 24(2)] are established.

**Table VI.8.** Process description - Transmission and rerouting of ICSRs to competent authorities in Member States <sup>44</sup>

| No. | Name                                      | Description   | Responsible Organisation |
|-----|---|---|--------------------------|
| 1   | <b>Start.<br/>Receive report.</b>         | <b>Marketing Authorisation Holder (MAH) receives information on a suspected adverse reaction from a patient, healthcare professional or other valid reporter.</b>   | <b>MAH</b>               |
| 2   | Open case.                                | Open and create an individual case safety report.   | MAH                      |
| 3   | Send to EudraVigilance (EV).              | Transmit the case electronically, in ICH E2B(R2) format as an xml message within the relevant time frames (15 or 90 days, as applicable), to EV.  | MAH                      |
| 4   | <b>Receive in EV.</b>                     | Receive the message in the EV.  | <b>EMA</b>               |
| 5   | Technical Validation (EV Business Rules). | Every message that is received in EV is validated against the EudraVigilance Business Rules and an Acknowledgement message (ACK) is created specifying whether or not the message & the case(s) therein are valid.<br>A valid message will have an ACK code 01. A non-valid message will have an ACK code 02 (if a case contained therein is non-valid) or 03 (if the message itself is not correctly formatted). | EMA                      |
| 6   | Store in EV.                              | Once the case has been validated, it is stored in EV.   | EMA                      |
| 7   | Send ACK.                                 | The acknowledgement message created in step 5 is transmitted to the case sender no later than 2 business days following receipt of the case.  | EMA                      |
| 7.1 | <b>Receive ACK.</b>                       | Receive the ACK message, associate it with the relevant case(s) and check to ensure that the case was considered valid.   | <b>MAH</b>               |
| 7.2 | Was ACK code 01?                          | If Yes, go to step 7.2.1.<br>If no, then the regulatory timeline clock has not stopped and the case should be corrected and re-transmitted to EV within the relevant regulatory reporting timelines. Day 0 remains as the day that the first information was received. A 02 or 03 ACK does not constitute new information. Go to step 7.2.2 (Correct  | MAH                      |

<sup>44</sup> Once the functionalities of the EudraVigilance database specified in [REG Art 24(2)] are established.

| No.   | Name                        | Description  | Responsible Organisation |
|-------|-----------------------------|--|--------------------------|
|       |                             | case).   |                          |
| 7.2.1 | End.                        | <b>End the process of transmitting this version of the case to EV. Normal follow-up activities should continue and if any follow-up is received, return to step 1.</b>   | MAH                      |
| 7.2.2 | Correct case.               | Correct the case to remove the errors identified in the ACK and retransmit the case to EV (go back to step 3).   | MAH                      |
| 8     | <b>Was ACK code 01?</b>     | If yes, go to step 9.<br>If no, perform no further processing on this version of the case and go to step 8.1   | EMA                      |
| 8.1   | Await corrected case.       | The sender should correct every case with an error ACK and retransmit it within the regulatory reporting timelines. Periodically the EMA should assess all cases with an error ACK for which a corrected case has not been transmitted and contact the Qualified Person responsible for Pharmacovigilance (QPPV) to inform of these missing corrected cases. If a sender fails to correct cases, his information should be incorporated into data quality assessments and the appropriate committees should be informed. | EMA                      |
| 9     | Assess cases in message.    | Whenever a message has passed the technical validation, the cases therein should be immediately assessed to determine the country where the reaction occurred for regulatory reporting purposes.   | EMA                      |
| 10    | Was case from EU?           | For every case, assess whether the country of occurrence is in the EU.<br>If Yes, go to step 11.<br>If No, go to step 10.1   | EMA                      |
| 10.1  | End.                        | <b>The case is now stored in EV &amp;, following duplicate detection &amp; recoding will be available for signal detection and data quality analyses.</b>  | EMA                      |
| 11    | Extract cases from message. | The cases occurring in the EU will be extracted from the message for processing prior to retransmission.   | EMA                      |
| 12    | Technical Validation.       | Message sender identifier (ICH M2 M.1.5) of reporting MAH is inserted in Sender organisation field (ICH-E2B(R2) A.3.1.2) prior to retransmission. This is to permit  | EMA                      |

| No.         | Name  | Description  | Responsible Organisation |
|-------------|---|--|--------------------------|
|             |   | the receiving National Competent Authority (NCA) to unambiguously identify the MAH responsible for transmitting the case to EV.  |                          |
| 13          | Send to relevant NCA                                | The case is transmitted to the relevant NCA of the Member State where the reaction occurred with no other changes. Where a Member State has more than one NCA responsible for post-marketing reports, the cases occurring in that Member State are sent to all relevant NCAs.  | EMA                      |
| <b>14</b>   | <b>Receive in Pharmacovigilance (PhV) database.</b> | The relevant NCA receives the message in its pharmacovigilance database  | <b>NCA</b>               |
| 15          | Technical Validation (EV Business Rules).           | Every message should be validated against the EudraVigilance Business Rules (the same business rules as in Step 5 and an Acknowledgement message (ACK) is created specifying whether or not the message & the case(s) therein are valid. A valid message will have an ACK code 01. A non-valid message will have an ACK code 02 (if a case contained therein is non-valid) or 03 (if the message itself is not correctly formatted). | NCA                      |
| 16          | Store in PhV database.                              | Once the case has been validated, it is stored in the pharmacovigilance database.  | NCA                      |
| 17          | Send ACK.   | The acknowledgement message created in step 15 is transmitted to EV no later than 2 business days following receipt of the case.   | NCA                      |
| <b>17.1</b> | <b>End</b>  | <b>The case is now stored in the NCA's pharmacovigilance database &amp;, following duplicate detection &amp; recoding will be available for signal detection and data quality analyses.</b>  | <b>NCA</b>               |
| 18          | Receive ACK   | The acknowledgement message sent in step 17 is received & stored in EV.  | EMA                      |
| <b>19</b>   | <b>End</b>  | <b>The case has now been successfully retransmitted to the relevant NCA.</b>   | <b>EMA</b>               |

2084

2085 **VI. Appendix 4 Transmission of ICSRs to World Health**  
 2086 **Organization (WHO)**<sup>45</sup>

2087 **Figure VI.6.** Business process map - Transmission of ICSRs to World Health Organization (WHO)  
 2088 Collaborating Centre for International Drug Monitoring

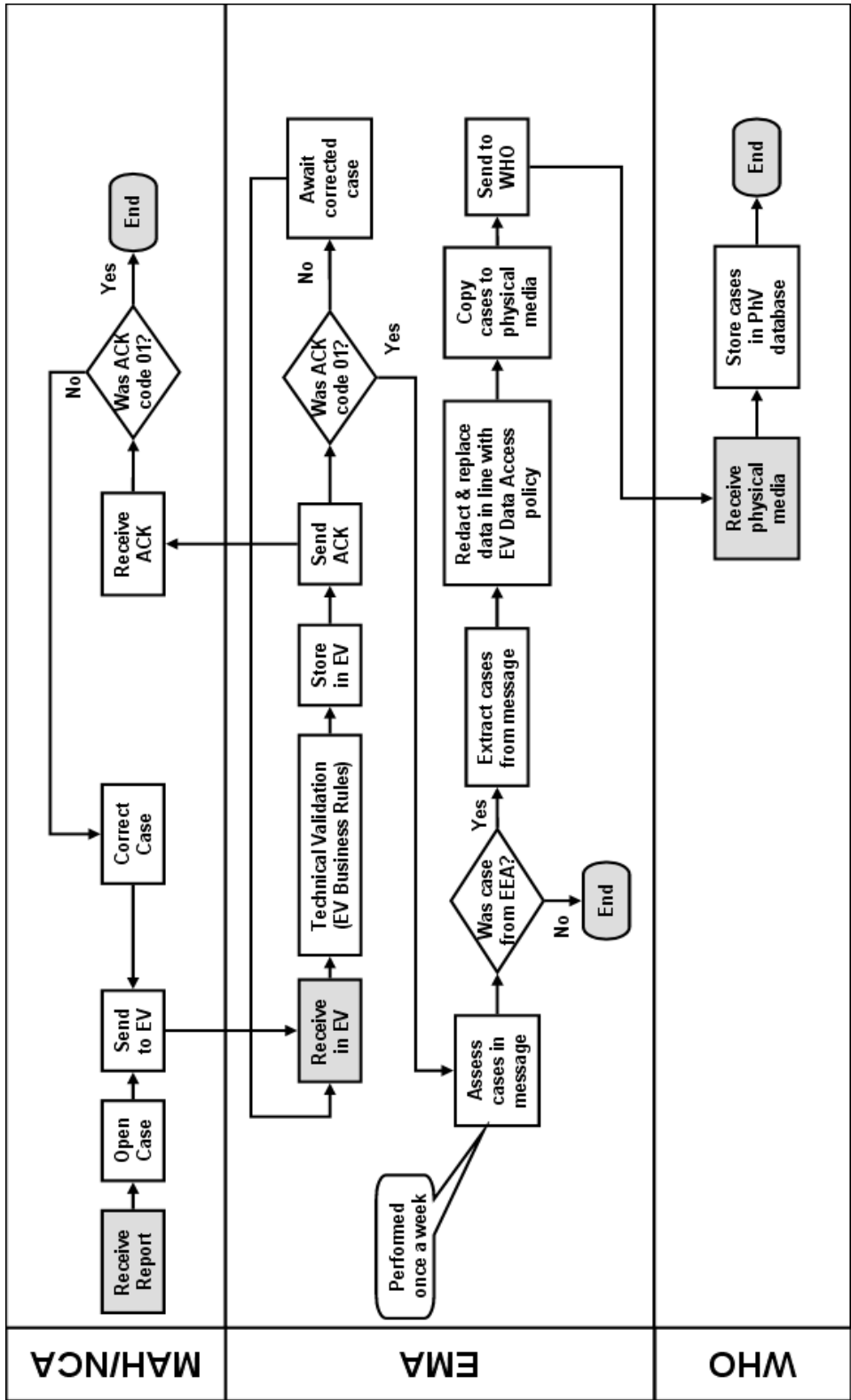

<sup>45</sup> Once the functionalities of the EudraVigilance database specified in [REG Art 24(2)] are established.

**Table VI.9.** Process description - Transmission of ICSRs to World Health Organization (WHO) Collaborating Centre for International Drug Monitoring<sup>46</sup>

| No. | Step                                      | Description   | Responsible Organisation |
|-----|---|---|--------------------------|
| 1   | <b>Start.</b><br><b>Receive report.</b>   | <b>National Competent Authority (NCA) or Marketing Authorisation Holder (MAH) receives information on a suspected adverse reaction from a patient, healthcare professional or other valid reporter.</b>   | <b>MAH/NCA</b>           |
| 2   | Open case.                                | Open and create an individual case safety report.   | MAH/NCA                  |
| 3   | Send to EV.                               | Transmit the case electronically, in ICH E2B(R2) format as an xml message within the relevant time frames (15 or 90 days, as applicable), to EudraVigilance (EV).   | MAH/NCA                  |
| 4   | <b>Receive in EV.</b>                     | <b>Receive the message in EV.</b>   | <b>EMA</b>               |
| 5   | Technical Validation (EV Business Rules). | Every message that is received in EV is validated against the EudraVigilance Business Rules and an Acknowledgement message (ACK) is created specifying whether or not the message & the case(s) therein are valid.<br>A valid message will have an ACK code 01. A non-valid message will have an ACK code 02 (if a case contained therein is non-valid) or 03 (if the message itself is not correctly formatted). | EMA                      |
| 6   | Store in EV.                              | Once the case has been validated, it is stored in EV.   | EMA                      |
| 7   | Send ACK.                                 | The acknowledgement message created in step 5 is transmitted to the case sender no later than 2 business days following receipt of the case.  | EMA                      |
| 7.1 | <b>Receive ACK.</b>                       | Receive the ACK message, associate it with the relevant case(s) and check to ensure that the case was considered valid.   | <b>MAH/NCA</b>           |
| 7.2 | Was ACK code 01?                          | If Yes, go to step 7.2.1.<br>If no, then the regulatory timeline clock has not stopped and the case should be corrected and re-transmitted to EV within the relevant regulatory reporting timelines. Day 0 remains as the day that the first information was received. A 02 or 03 ACK does not constitute new information. Go to step 7.2.2 (Correct  | MAH/NCA                  |

<sup>46</sup> Once the functionalities of the EudraVigilance database specified in [REG Art 24(2)] are established.



| No.   | Step  | Description  | Responsible Organisation |
|-------|---|--|--------------------------|
|       |   | case).   |                          |
| 7.2.1 | End   | <b>End the process of transmitting this version of the case to EV. Normal follow-up activities should continue and if any follow-up is received, return to step 1.</b>   | MAH/NCA                  |
| 7.2.2 | Correct case  | Correct the case to remove the errors identified in the ACK and retransmit the case to EV (go back to step 3).   | MAH/NCA                  |
| 8     | <b>Was ACK code 01?</b>                                   | If yes, go to step 9<br>If no, perform no further processing on this version of the case and go to step 8.1  | EMA                      |
| 8.1   | Await corrected case.                                     | The sender should correct every case with an error ACK and retransmit within the regulatory reporting timelines. Periodically the EMA should assess all cases with an error ACK for which a corrected case has not been transmitted and contact the Qualified Person responsible for Pharmacovigilance (QPPV) to inform of these missing corrected cases. If a sender fails to correct cases, this information should be incorporated into data quality assessments and the appropriate committees should be informed. | EMA                      |
| 9     | Assess cases in message.                                  | Once a week, for every message that has passed the technical validation, the cases therein should be assessed to determine the country where the reaction occurred for regulatory reporting purposes.  | EMA                      |
| 10    | Was case from EU?   | For every case, assess whether the country of occurrence is in the EU.<br>If Yes, go to step 11.<br>If No, go to step 10.1.  | EMA                      |
| 10.1  | End.  | <b>The case is now stored in EV &amp;, following duplicate detection &amp; recoding will be available for signal detection and data quality analyses.</b>  | EMA                      |
| 11    | Extract cases from message                                | The cases occurring in the EU is extracted from the message for processing prior to retransmission.  | EMA                      |
| 12    | Redact & replace data in line with EV Data Access policy. | Prior to sending the cases to the World Health Organisation (WHO) Collaborating Centre, the extracted copies of the cases have some data elements redacted and replaced in line with the EV Data Access  | EMA                      |

| No.       | Step   | Description   | Responsible Organisation |
|-----------|--|---|--------------------------|
|           |  | Policy in order to ensure personal data protection.   |                          |
| 13        | Copy cases to physical media.                    | The cases are copied to physical media.   | EMA                      |
| 14        | Send to WHO.                                     | The physical media is sent to WHO Collaborating Centre.   | EMA                      |
| <b>15</b> | <b>Receive physical media</b>                    | <b>WHO Collaborating Centre receives the physical media.</b>  | <b>WHO</b>               |
| 16        | Store cases in pharmacovigilance (PhV) database. | Once the cases have been validated, they are stored in the pharmacovigilance database.  | WHO                      |
| <b>17</b> | <b>End.</b>                                      | <b>Cases are stored in the WHO Collaborating Centre's pharmacovigilance database &amp; following duplicate detection &amp; recoding will be available for signal detection and data quality analyses.</b> | <b>WHO</b>               |

2092

2093 **VI.Appendix 5 Nullification of cases**

2094 General principles regarding the nullification of cases are provided in [VI.C.6.2.2.10](#). The following  
 2095 recommendations should also be applied:

- 2096 • The value in the data element ‘Report nullification’ (ICH-E2B(R2) A.1.13) should be set to ‘Yes’ and  
 2097 the nullification reason should be provided in the data element ‘Reason for nullification’ (ICH-  
 2098 EB(R2) A.1.13.1). The nullification reason should be clear and concise to explain why this case is  
 2099 no longer considered to be a valid report. For example a nullification reason stating, ‘the report no  
 2100 longer meets the reporting criteria’ or ‘report sent previously in error’ are not detailed enough  
 2101 explanations.
- 2102 • An individual case can only be nullified by the sending organisation.
- 2103 • Once an individual case has been nullified, the case cannot be reactivated.
- 2104 • If it becomes necessary to resubmit the case that has been previously nullified, a new ‘Sender’s  
 2105 (case) safety report unique identifier’ (ICH-E2B(R2) A.1.0.1) and ‘Worldwide unique case  
 2106 identification number’ (ICH-E2B(R2) A.1.10) should be assigned.
- 2107 • Individual versions (i.e. follow-up reports) of a case cannot be nullified, only the entire individual  
 2108 case to which they refer.

2109 **Table VI.10.** Examples of scenarios for which ICSRs should be nullified

| Ex. | Scenario  | Action  |
|-----|---|---|
| 1   | An individual case has been identified as a duplicate of another individual case previously submitted.  | One of the individual cases should be nullified. The remaining valid case should be updated with any additional relevant information from the nullified case.   |
| 2   | A wrong ‘Worldwide unique case identification number’ (ICH-E2B(R2) A.1.10) was accidentally used and does not refer to an existing case.  | The case with the wrong ‘Worldwide unique case identification number’ (ICH-E2B(R2) A.1.10) should be nullified.<br><br>A new case should be created with a correct ‘Worldwide unique case identification number’. |
| 3   | On receipt of further information it is confirmed that that the adverse reaction occurred before the suspect drug(s) was taken.   | The case should be nullified.   |
| 4   | On receipt of further information on an individual case, it is confirmed that the patient did not receive the suspect drug. Minimum reporting criteria for an ICSR as outlined in <a href="#">VI.B.2</a> are no longer met. | The case should be nullified.   |
| 5   | On receipt of further information it is confirmed by the same reporter that the reported adverse reaction(s) did not occur to the patient. Minimum reporting  | The case should be nullified.   |

| Ex. | Scenario   | Action  |
|-----|--|---|
|     | criteria for an ICSR as outlined in <a href="#">VI.B.2</a> are no longer met.  |   |
| 6   | On receipt of further information it is confirmed that there was no valid patient for the individual case. Minimum reporting criteria for an ICSR as outlined in <a href="#">VI.B.2</a> are no longer met. | If it is not possible to obtain confirmation of the patient's existence, then the case should be nullified. |

2110 • Individual cases that have been nullified should not be used for scientific evaluation, however, they  
2111 should remain in the database for auditing purposes.

2112 • In addition, in case of duplicate reports where one report needs to be nullified, the update of the  
2113 remaining case should be performed in the form of a follow-up report<sup>47</sup>. Information on the  
2114 identification of the nullified case(s) should be provided in the data element 'Source(s) of the case  
2115 identifier (e.g. name of the company, name of regulatory agency)' (ICH-E2B(R2) A.1.11.1 ) and in  
2116 the data element 'Case identifier(s)' (ICH-E2B(R2) A.1.11.2).

2117 **Table VI.11.** Examples of scenarios for which ICSRs should NOT be nullified

| Ex. | Scenario   | Action   |
|-----|--|--|
| 7   | A wrong 'Worldwide unique case identification number' (ICH E2B(R2) A.1.10) was accidentally used. This wrong ICH-E2B(R2) A.1.10 'Worldwide unique case identification number' referred to an existing case.  | The report with the wrong 'Worldwide unique case identification number' (ICH-E2B(R2) A.1.10) should not be nullified.<br><br>A follow-up report should be submitted to correct the information previously submitted.<br><br>A new ICSR should be created and submitted with the correct 'Worldwide unique case identification number'. |
| 8   | On receipt of further information on an individual case, it is confirmed that the patient did not receive the marketing authorisation holder's suspect drug. However, the patient received other suspect drugs and the minimum reporting criteria for an ICSR are still met. | The case should not be nullified.  |
| 9   | On receipt of further information the reporter has confirmed that the reported adverse reaction is no longer considered to be related to the suspect medicinal product(s).   | The case should not be nullified.<br><br>A follow-up report should be submitted within the appropriate time frame with the updated information on the case.  |

<sup>47</sup> As presented in the [Guideline on the Detection and Management of Duplicate Individual Cases and Individual Case Safety Reports \(ICSRs\)](#), [EMA/13432/2009](#).

| Ex. | Scenario  | Action  |
|-----|---|---|
| 10  | Change of the individual case from serious to non-serious (downgrading).  | <p>The case should not be nullified.</p> <p>A follow-up report should be submitted with the data element 'Seriousness' (ICH-E2B(R2) A.1.5.1) populated with the value 'No' without selection of a value for the data element 'Seriousness criteria' (ICH-E2B(R2) A.1.5.2).</p> <p>The data element 'Does this case fulfil the local criteria for an expedited report?' (ICH-E2B(R2) field A.1.9) should remain populated with the value 'Yes'.</p>  |
| 11  | The primary source country has changed, which has an impact on the ICH-E2B(R2) convention regarding the creation of the 'Worldwide unique case identification number' (ICH-E2B(R2) A.1.10). | <p>The case should not be nullified.</p> <p>The 'Sender's (case) safety report unique identifier' (ICH-E2B(R2) A.1.0.1) can be updated on the basis of the new primary source country code. However, the 'Worldwide unique case identification number' (ICH-E2B(R2) A.1.10) should remain unchanged.</p> <p>If, for some technical reason, the sender's local system is not fully ICH-E2B(R2) compliant and cannot follow this policy, then the sender should nullify the original case. A new case should be created with a new 'Worldwide unique case identification number' (ICH-E2B(R2) A.1.10) reflecting the changed primary source country code. The 'Worldwide unique case identification number' (ICH-E2B(R2) A.1.10) of the case that was nullified should be reflected in the data elements 'Other case identifiers in previous transmissions' (ICH-E2B(R2) A.1.11).</p> |
| 12  | The suspected medicinal product belongs to another marketing authorisation holder (e.g. a product with the same active substance but marketed under a different invented name).             | <p>The case should not be nullified.</p> <p>It is recommended that the initial sender informs the other marketing authorisation holder about this case (including the 'Worldwide unique case identification number' (ICH-E2B(R2) A.1.10) used). The original organisation should also submit a follow-up report to provide this new information.</p> <p>The other concerned marketing authorisation holder should create a new case and specify the reference case number and the name of the initial sending marketing authorisation holder in the data elements 'Source(s) of the case identifier (e.g. name of the company name of regulatory agency)' (ICH-E2B(R2) A.1.11.1) and 'Case identifier(s)' (ICH-E2B(R2) A.1.11.2). This will allow grouping the cases in the EudraVigilance database.</p>  |

| Ex. | Scenario   | Action  |
|-----|--|---|
| 13  | The suspected medicinal product taken does not belong to the marketing authorisation holder (same active substance, the invented name is unknown and the report originates from a country, where the marketing authorisation holder has no marketing authorisation for the medicinal product in question). | <p>The case should not be nullified.</p> <p>The marketing authorisation holder should submit a follow-up report with this information within the appropriate time frame.</p>  |
| 14  | The case is mistakenly reported by the marketing authorisation holder A although the marketing authorisation holder B as co-marketer is responsible for reporting the case.  | <p>The case should not be nullified.</p> <p>An explanation should be sent by the marketing authorisation holder A to the co-marketer marketing authorisation holder B that the case has already been reported. The marketing authorisation holder B should provide any additional information on the case as a follow-up report with the same 'Worldwide unique case identification number' (ICH-E2B(R2) A.1.10).</p> |

2118

2119 **VI.Appendix 6 Data quality monitoring of ICSRs transmitted electronically**  
 2120

2121 **Figure VI.7.** Business process map - Data quality monitoring of ICSRs transmitted electronically

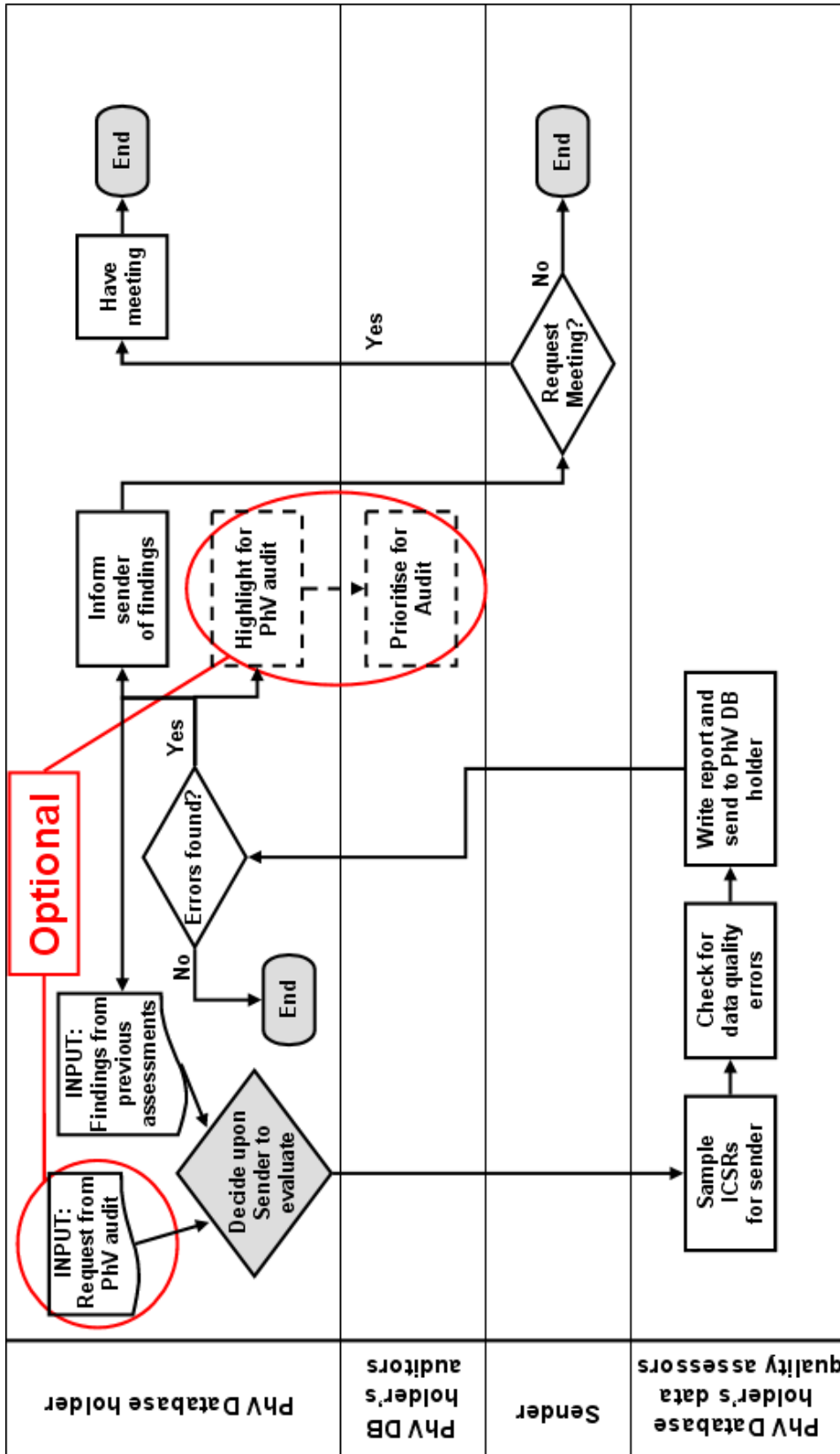

2122

2123 **Table VI.12.** Process description - Data quality monitoring of ICSRs transmitted electronically

2124 The business map and process description describe a system where there is a separation between a  
 2125 Pharmacovigilance DataBase (PhV DB) holder, the PhV DB holder's data Quality Assessors (QA) and  
 2126 the PhV DB holder's auditors; however this is not mandatory and these functions may be performed by  
 2127 the same people or groups.

| No. | Step  | Description   | Responsible Organisation |
|-----|---|---|--------------------------|
| 1   | <b>Start.</b><br><b>Decide upon Sender to evaluate.</b> | <b>Select one of the organisations that has transmitted ICSRs to your database.</b><br><b>Inputs into this decision can include, but need not be limited to findings from previous assessments and requests from pharmacovigilance audits.</b>  | <b>PhV DB holder</b>     |
| 2   | <b>Sample ICSRs from Sender.</b>                        | Take a sample of ICSRs that were transmitted by the selected sender   | <b>QA</b>                |
| 3   | Check for data quality errors.                          | Check the cases for data quality errors. The cases should be assessed against appropriate published standards and similar documents, for example the MedDRA Term Selection Points to Consider document.   | QA                       |
| 4   | Write report and send to PhV DB holder.                 | The findings from the data quality assessment should be collated into a single report. These can include related checks, such as 15-day reporting compliance, whether error reports are corrected and similar statistical information.  | QA                       |
| 5   | <b>Errors found?</b>                                    | Were any errors found during the analysis of the cases?<br>If No, go to step 5.1.<br>If Yes go to steps 5.2, 5.3 & 6.   | <b>PhV DB holder</b>     |
| 5.1 | <b>End.</b>   | <b>If there were no errors found, then no further action needs to be taken. The process can end until the next time the sender is assessed. The pharmacovigilance database (PhV DB) holder may choose to share this information with the assessed sender and their auditors who may wish to factor this in to determinations of which sender to assess.</b> | <b>PhV DB holder</b>     |
| 5.2 | Highlight for PhV audit.                                | If the PhV DB holder's organisation has an audit department, any significant findings   | PhV DB holder            |



| No.   | Step  | Description  | Responsible Organisation          |
|-------|---|--|-----------------------------------|
|       |   | should always be shared with them.   |                                   |
| 5.2.1 | <b>Prioritise for Audit.</b>                          | The audit or inspections department should use the information provided to them to feed into decisions about prioritising organisations for audit or inspection.   | <b>PhV DB holder's auditors</b>   |
| 5.3   | <b>INPUT: Findings from previous assessments.</b>     | Any errors found (or even lack thereof) should be incorporated into decisions about which senders to evaluate & should also inform the performance of the assessments (e.g. targeting particular types of case) and the report (documenting whether previously identified issues have been addressed). | <b>PhV DB holder</b>              |
| 6     | Inform sender of findings.                            | Inform the sender of the findings, including requested remedial actions (e.g. retransmitting certain cases) and time frames for those actions  | PhV DB holder                     |
| 7     | <b>Request meeting?</b>                               | The sender should have the option to choose to request a meeting to discuss the findings and appropriate remedial action and time frames.<br>If no meeting is requested, go to step 7.1.<br>If a meeting is requested go to step 8.  | <b>Sender</b>                     |
| 7.1   | Address the findings & retransmit any required cases. | Address all findings, take necessary steps to prevent recurrence of such findings & retransmit any required cases.   | Sender                            |
| 7.2   | <b>End.</b>   | <b>Once all findings have been addressed, the necessary steps taken to prevent recurrence of such findings and any required cases have been retransmitted, the process can end until the next time the sender is assessed.</b>   | <b>Sender</b>                     |
| 8     | <b>Have meeting.</b>                                  | Upon request from one party, a meeting should be held to discuss the findings of quality assessments and appropriate remedial and preventive actions to ensure that the cases in the database are correct and shall be so in the future.   | <b>PhV DB holder &amp; Sender</b> |
| 9     | <b>End.</b>   | <b>Unless further action has been specified (e.g. future meetings or assessments), the process can end until the next time the sender is assessed.</b>   | <b>PhV DB holder</b>              |

2129

## VI. Appendix 7 Duplicate detection and management of ICSRs

2130

Figure VI.8. Business process map - Duplicate detection and management of ICSRs

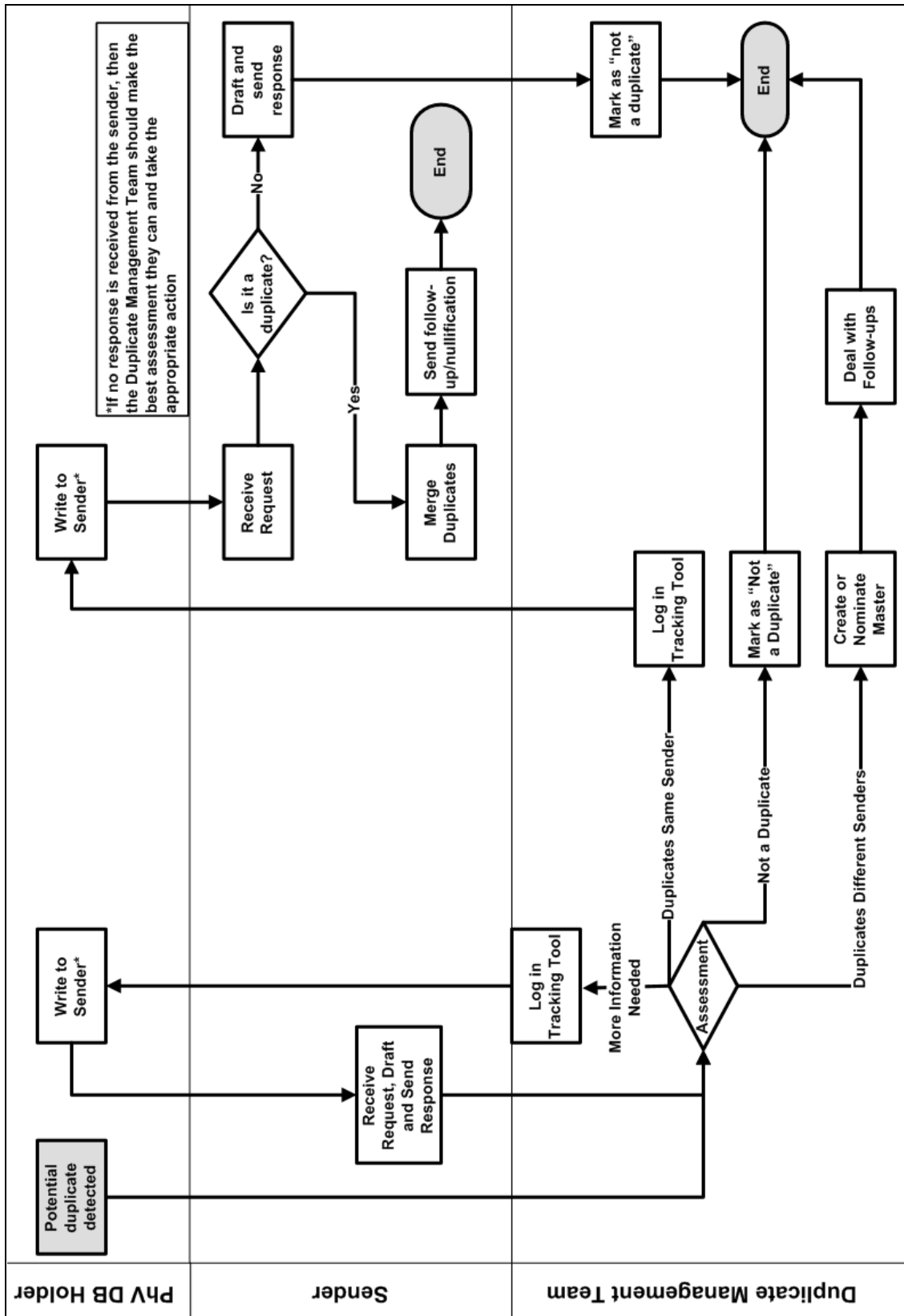

2131

2132 **Table VI.13.** Process description - Duplicate detection and management of ICSRs

| No.   | Step  | Description   | Responsible organisation |
|-------|---|---|--------------------------|
| 1     | <b>Start.</b><br><b>Potential duplicate detected.</b> | <b>Potential duplicates have been detected by the Pharmacovigilance Database (PhV DB) holder organisation or the PhV DB holder organisation is notified of potential duplicates by a receiver of the cases.</b>   | <b>PhV DB holder</b>     |
| 2     | <b>Assessment.</b>                                    | <p><b>All potential duplicates need assessment by the organisation Duplicate Management Team (DMT) to confirm or deny their duplicate status.</b></p> <p>Following assessment there are 4 possible outcomes:</p> <ul style="list-style-type: none"> <li>• Not a Duplicate (go to step 2.1),</li> <li>• More Information Needed (go to step 2.2),</li> <li>• Duplicates From Different Sender (go to step 2.3),</li> <li>• Duplicates From Same Sender (go to step 2.4).</li> </ul> <p>The outcome of all assessments should be recorded to avoid continually reassessing the same cases when further versions arrive. These recorded outcomes can also be used to refine the duplicate detection methods during future development.</p> | <b>DMT</b>               |
| 2.1   | Not a Duplicate: Mark as not a duplicate.             | If the cases are assessed as not being duplicates of one another, then mark both cases as such.<br>Go to step 3 (End).  | DMT                      |
| 2.2   | More information needed: Log in tracking tool.        | There should be some form of tool for tracking when more information is needed, when correspondence has been sent, whether an answer was received and, if so, when.   | DMT                      |
| 2.2.1 | <b>Write to Sender.</b>                               | More information is required in order to be able to make a definite assessment. The sender (who transmitted the case(s) in question to the PhVDB holder's organisation) should be contacted to request specific information necessary to confirm or deny duplication. Personal data protection must remain paramount, so unsecured communications should not include sufficient data to   | <b>PhV DB holder</b>     |

| No.          | Step  | Description  | Responsible organisation |
|--------------|---|--|--------------------------|
|              |   | identify an individual.  |                          |
| 2.2.2        | <b>Receive request, draft and send response.</b>                | Once a request for more information has been received, the Sender of the case should respond promptly, either as a follow-up version of the case or by responding to the requester.<br>The DMT should then reassess the case based on the new information (Go back to step 2).   | <b>Sender</b>            |
| <b>2.3</b>   | <b>Duplicates Different Senders: Create or nominate master.</b> | Once cases have been determined to be duplicates of one another and have been transmitted to the PhV DB holder by different senders or reporters, then they should be merged under a master case, following the process described in chapter 2.3 "Management of duplicate cases" of the Guideline on the Detection and Management of Duplicate Individual Cases and Individual Case Safety Reports (ICSRs), <a href="#">EMA/13432/2009</a> . | <b>DMT</b>               |
| 2.3.1        | Deal with follow-ups.   | If any follow-ups arrive for any of the cases, this information may require a reassessment of the master case.<br>Reassess and, if necessary, amend the master case as with any received follow-up information.<br>Go to step 3 (End).   | DMT                      |
| <b>2.4</b>   | <b>Duplicates Same Sender: Log in tracking tool.</b>            | Once cases have been determined to be duplicates of one another, and have been transmitted to the PhV DB holder by the same sender, then this decision and the correspondence referred to in step 2.4.1 should be logged in the tracking tool referred to in step 2.2.   | <b>DMT</b>               |
| <b>2.4.1</b> | <b>Write to Sender.</b>   | The sender organisation, as the source of the duplicates, should be contacted in accordance with chapter 2.3.3 of the Guideline on the Detection and Management of Duplicate Individual Cases and Individual Case Safety Reports (ICSRs), <a href="#">EMA/13432/2009</a> .<br>The sender should be asked to confirm or deny duplication and take appropriate steps in accordance with chapter 2.3.1 of the aforementioned Guideline.         | <b>PhV DB holder</b>     |
| <b>2.4.2</b> | <b>Receive request.</b>   | Receive and log the communication  | <b>Sender</b>            |

| No.       | Step                          | Description  | Responsible organisation |
|-----------|-------------------------------|--|--------------------------|
|           |                               | containing information on suspected duplicates in the Sender's PhV DB.   |                          |
| 2.4.3     | Is it a duplicate?            | Assess the potential duplicates. Are the cases duplicates of one another?<br>If Yes, go to step 2.4.3.1.<br>If No, go to step 2.4.3.2.   | Sender                   |
| 2.4.3.1   | Merge duplicates.             | Merge the duplicates, taking into account Flowchart 1 of chapter 2.3.1.3 of the Guideline on the Detection and Management of Duplicate Individual Cases and Individual Case Safety Reports (ICSRs), <a href="#">EMA/13432/2009</a> .   | Sender                   |
| 2.4.3.1.1 | Send follow-up/nullification. | For the cases that are merged under the master, send a nullification message to the PhV DB holder.<br>For the case that is master, send the updated case to the PhV DB holder as follow-up information. The merging & transmission should be completed promptly and in any case within 15 days of the date of receipt of the information from the PhV DB holder that the cases were considered to be possible duplicates. This date should be treated as the date of receipt of most recent information for regulatory reporting purposes. | Sender                   |
| 2.4.3.1.2 | End.                          | <b>The duplicates have now been removed from both the Sender's system and that of the PhV DB holder and only the master should be available for signal detection and data quality analyses. Unless follow-up information is received, then no further steps need be taken.</b>   | Sender                   |
| 2.4.3.2   | Draft and send a response.    | Reply to the PhV DB holder who sent the communication informing that the cases are not duplicates.   | Sender                   |
| 2.4.3.2.1 | Mark as "Not a duplicate".    | Upon receipt of confirmation from the Sender organisation that the cases are not duplicates, mark the cases as "Not a duplicate" & go to step 3 (End).   | DMT                      |
| 3         | End.                          | <b>No further action is required for this couple.</b>  | DMT                      |